

"How to Build an Iguana Cage"

Click on the image or link below to go to the booklet you want.

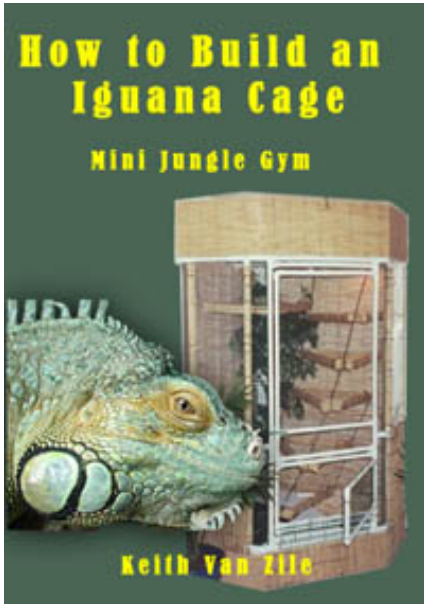

[Mini Jungle Gym](#)



[Big Jungle Gym](#)

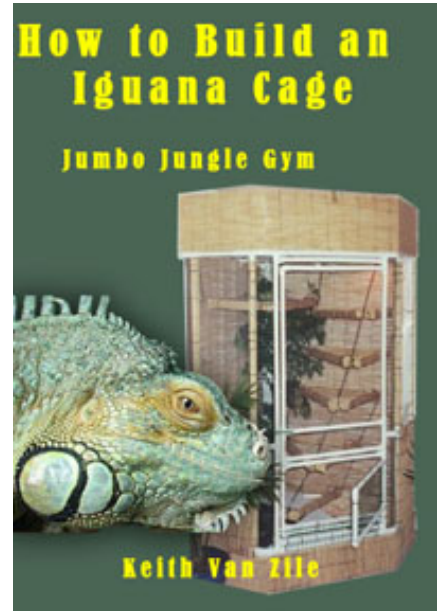

[Jumbo Jungle Gym](#)

How to Build an Iguana Cage

Mini Jungle Gym



[Main Index](#)

Mini Jungle Gym

Contents

[Introduction](#)

[Materials & Measurements List](#)

[Tools](#)

[Measurements](#)

[Building the Mini Jungle Gym](#)

[The Frame](#)

[The Door](#)

[The Ceiling](#)

[Back Panels](#)

[Windows](#)

[Basking Hammock and Shelves](#)

[Floor Alternatives](#)

Introduction

These plans have been compiled from material supplied with permission from Keith Van Zile. They are intended as a guide to creating cages suitable for Iguanas, chameleons and a range of other animals. As with any captive animal it is the responsibility of the owner to create the best possible habitat and conditions for the animals within their care.

Considerable time and expense has gone into creating these plans.

For best results it is recommended that you read through the plans in their entirety before starting to construct the cages.

If you become frustrated or have difficulties, walk away for about 30 min and do something else. Many times when you come back to a difficulty, you will be rewarded with a solution, or at least a better frame of mind.

Have fun with these plans and enjoy your time building something you will be proud of.

Materials & Measurements List

Tools

Here are the tools you'll need:

(1) pvc cutting tool.

For hand tools, I like the Ridge Tool Company unit (about \$14), but some people like the tool that looks more like a pruning shear for pvc. They both work well.

I'd avoid attempting to cut all the pvc with a hack saw -- you'll wear yourself out! A jig saw works fine for cutting the pvc, too.

(1) Orbital Jig Saw (about \$29 at Kmart)

(1) measuring tape

(1) pair clipping pliers

(1) sanding block

(1) drill

(1) straight-edge

(1) pair strong scissors

Measurements (coordinated with the plans):

Each of the lettered pieces below corresponds with a piece in the plan. Do not worry about this too much at this stage. The plans will have each of these with the correct measurement in the appropriate place. These are used when designing the original plans.

[A] 13 lengths of PVC pipe

[B] 41 1/2"

[C] 22 1/2"

[D] 13 3/4"

[E] 1 1/2"

[F] 12

[G] 26"

[H] 24 3/4"

[I] 16 1/4"

[J] 5"

[K] 35 1/2"

[L] 25 3/4"

[M] 3"
[N] 10 1/4"
[O] 23 1/2"
[P] 4 1/2"
[Q] 24 1/2"
[R] 43" x 25"
[S] 9"
[T] 10" x 25"
[U] 33" x 68"
[V] 6 1/2" x 43"
[W] 6 1/2" x 24"
[X] 6 1/2"
[Y] 15" x 25"
[Z] 32" x 44"
[AA] 15 1/4 x 43 3/4"
[BB] 26" x 44"

Materials: (approx. total cost: \$175)

3/4" PVC Poles: (~\$10)

Home Depot and Lowes sell them in 10' lengths.

You'll need 12, including one for the basking shelf, but I'd suggest getting **13**, so you have a little extra for more shelves and any mistakes.

They're only .77 cents each at Lowes. If you have a choice between thicker or thinner poles, I suggest using the thinner ones, labeled 'Class 200' unless you use a power saw to cut them. The thinner ones still provide plenty of cage strength since the panel-based design provides lots of structural support.

Tip:

Masking tape is a handy way to hold the bundle of poles together to transport them at the store.

3/4" PVC Pipe Connectors:

These are all the T connectors and Elbows and Angles that you'll find in the plumbing department at Home Depot.

Here's what you'll need:

Number	Part
33	T connectors (these are all for 3/4" pvc) (~\$10)
24	45 degree angle connectors 3/4" (~\$8)
10	4-way T connectors 3/4" (known as: "4 way cross") (~\$16)
8	90 degree angle connectors 3/4" (corners) (4 are for basking shelf, 4 are for the double door). (~\$3)
8	T connectors - marked: 1" x 1" x 3/4" (these are for around the door. A jig saw will be required to cut them in half. You can see how in the plans and pictures.) This includes the 4 required for the lower door-within-a-door.

[Contents](#)

Paneling

For the back panels, I use shiny white 1/8" paneling. This 'White Tile Board', is sold in 4x8 sheets, (1/8" thick) for about \$10 per sheet at most Home Depots.

Tip:

Home Depot will cut the panels to size FOR you, if you ask.

It comes in different designs, too, if you prefer something other than plain white.

You'll need one sheet to get the large back panel, the ceiling and the lower side panels from, and a second sheet to get the narrow corner pieces - unless you opt to make those from clear lucite or cable-tie in plastic mesh.

The dimensions to have Home Depot cut from one sheet of the white paneling are:

- (1) 43" x 25" -- for the ceiling.
- (1) 68" x 33" -- for the back panel.
- (2) 25" x 15" -- for the lower front side panels - under the windows.

I usually sketch it out on a piece of paper first - just to make it easy for them.

Alternatives

From a second sheet - or from clear Lucite - cut these narrow corner panels:

- (4) 43" x 6 1/2" -- for the upper corners.
- (4) 24" x 6 1/2" -- for the lower corners.

If you have them cut these narrow corner pieces from a second sheet of tile board, you'll have plenty left over to make an oversized floor, measuring: 48" x 30".

Alternative Floor

As for the floor... Essentially, the best floor idea is to replace several of the T connectors around the cage base with 4 way cross connectors, so that 8" pvc "legs" can be installed with 3/4" caps on the ends - or even better: 90 degree angles that connect the legs together with floor "skid" poles.

Then a false floor of the 1" green mesh can be made and suspended in place. This would make a poop-through, very secure floor.

By using velcro loops to hold it in place about 8" above the actual floor, it could be easily removed for cleaning or to give access to a water tub.

The narrow openings on the right and left side of the door are 3" wide. You could use clear lucite - or even plastic mesh lashed to the 6' bamboo poles with twine (my favorite choice) or just cable-tied it in place.

Cable Ties

You'll need a minimum of 100 white 7.5" cable ties to complete the cage and basking shelf. They're in the electrical department at Home Depot. While you're there, you might also pick up 2 dome lights, 2 timers and a surge protector, along with a grounded extension cord long enough to reach from the cage to your outlet. Get 3 timers if you want your UVb fixture on automatic also.

Front Doors & Windows

For the clear front door window and two side windows, I buy two Lucite or other acrylic panels in sheets of 32" x 44" for about \$13 each. Cut in half, one sheet yields the two side windows and the other sheet can cover the front door.

For the lower door-within-a door, plastic mesh works fine - although one easy alternate option is to get one sheet of Lucite 72" x 36" (for about \$36) and make the whole door clear, instead of making the lower door-within-a-door.

If you opt to use a 32" x 44" sheet for the door, just cut a 6" piece off the long way, and drill holes for cable ties in the

corners and every 12" or so, 1/2" in from the edge. That 6" piece left over can then be used to make one of the front corner panels.

An orbital jig saw is the easiest method I've found to cut the Lucite, although you can also score both sides deeply and snap a clean line - if you're lucky.

A sharp drill bit used slowly and very carefully makes clean holes. I recommend drilling through the Lucite into a piece of scrap wood underneath to avoid cracking the Lucite. I've found that the least expensive acrylic (Lucite) panels work fine as windows.

Mesh and Bamboo for Climbing Sections

One roll of green plastic "MultiNet" will give you plenty of mesh for the basking shelf and any additional shelves or panels that you wish to use it for. You could even line the whole cage with mesh - since it comes in a 25' x 40" roll for about \$8. It's a 1" square green mesh in the Landscaping department at Home Depot called MultiNet.

If your lizard is small, I'd suggest using the dark green 1/2" plastic mesh from Lowes. Either one cuts easily with strong scissors or cutting pliers (clippers).

If you can't find a roll of bamboo 'Natural Reed Fencing', you can use any suitable alternative, such as 4x6 foot Matchstick Blinds, which is just enough to cover the shelves, or even some brown or green indoor/outdoor carpeting. The bamboo cuts relatively easily with strong scissors or tin snips. Home Depot can transfer a roll to your local store from a store that stocks it, for example, from almost any Home Depot in Florida. It comes in a 6' x 15' roll for \$19.95.

That gives you more than enough bamboo for shelves and lots of cage trim. Home Depot sells it as item # 325-538. They tell me that they will transfer it from any West Palm store to any other HD at no charge as an In-store transfer. The HD in West Palm is: 561-683-7221. It's store #6320. Lowes sells it as item #147448 for \$29.95.

I use 11" black cable ties (Qty: 25) to hold the bamboo on the basking shelf. I cover the pvc frame with 3/4" pipe insulation (those long black foam tubes - you'll need just (1) 6' length - marked 'For 3/4" copper pipe'). It gives the pvc shelf frame some thickness under the bamboo. If you plan to make the hanging corner shelves, you'll need additional materials: chain, pvc, insulation, cable ties and connectors.

Tip:

When you clip the tail off of the cable ties once they're in place, pull on the tail end hard while clipping it, so that you don't leave a sharp edge. The remaining tail snaps back into the cable tie square - giving it a "smooth shave" and no sharp edge sticking out.

The ceiling takes 2 chrome rings (under \$5 each) which are actually stove trim rings: 8" trim rings from GE. Part number: PM31X105. At Home Depot. Recessed lighting rings also work fine.

You'll also need a small roll of un-coated wire cloth, if you want a barrier between the lights and your cage. 1/4" wire cloth works well, although smaller gauges are even easier to work with. You'll need one 10" x 25" swath - or two 10" x 10" pieces of the wire cloth for your ceiling light mounts. The 2 chrome rings (under \$5 each) are actually stove trim rings: 8" trim rings from GE. Part number: PM31X105. At Home Depot. Recessed lighting trim rings also work well, if you'd prefer those.

Chains

You'll also need chains. Home Depot and Lowes will cut the Black Decorative chain to length for you. Get 5 feet for the basking shelf. Get 23 feet if you also want to make the stack of five hanging shelves. It runs about \$.60/ft. (~\$15)

For the front door, get two narrow 3" bolts. For convenience, you may want to attach small cords to them with twine and tie them to the cage, so that they don't get lost. If you opt to make a lower door-within-a-door, get one 4 1/2" bolt instead of one of the 3" bolts. The nuts aren't really necessary - the bolts are sufficient to pin the door closed.

[Contents](#)

Building the Mini Jungle Gym

**The dimensions of this enclosure are:
3.5 feet wide, 2.5 feet deep and 5.75 feet tall.**



The Frame

For this enclosure, you'll need to buy 13 x 10' lengths of 3/4" pvc:

You will need to make 4 panels.

For each panel you need the following:

Cut the pvc pipe into two lengths of 41 1/2" [B] and two lengths of 22 1/2" [C] and three lengths of 13 3/4" [D].



The connectors are two Ts on top two Ts on the bottom and two 4-way crosses in the middle.



The trick to putting them together is to twist them in.

PVC can be pushed into a connector up to 3/4", but I would suggest going in only 1/2" for now.



You can always tighten and straighten everything up later - once all the panels are together.

**The trick to
that is to
use your
weight to
lean on
them,
because
there's no
way to
muscle
these
joints tight.**

**Glue isn't
necessary,
since a
friction fit
is plenty
strong -
and who
knows,
you just
might want
to take this
cage apart
someday!**

**After you
have made
four
panels,
and made
them
match
each
other...
your cage
can start to
take shape
by
connecting
the panels
to each
other with
corners.**

Corners are just two forty-five degree angle connectors joined by a 1 1/2" length of pvc with two more pvc plugs in the ends.

You'll need to make 12 sets of corners.

Go ahead and connect all the panels now.

Here's the shape you're looking for:

The two back panels are joined with 1 1/2" [F] sections of pvc, leaving no space between the panel connectors.



Cut two more 41 1/2" [B], two more 22 1/2" [C] poles.

Connect them as shown to turn the front corners.

They form the opening where the door will be attached.



Now you have the basic cage shape together:

Next we'll tackle the door...

Building the Mini Jungle Gym Front Door

The Front Door is a truly great feature of these cages.

The working hinges are a real convenience, since you need to get in and out of your lizard's enclosure several times each day, and lower second door is a very handy addition.

Okay, let's get started. We've got the frame all together right?

So, let's add the top and bottom of the door, to complete the cage frame shape.



Cut two 26" [G] poles from the 3/4" pvc.

Put the T connectors on the ends of each pole.

Go ahead and put them in to complete the frame shape.



Now it's time to get down to the door construction itself.

Here's what it looks like completed... for reference.



Let's build from the bottom up. To make the lower section of the door:

Cut two 24 3/4" [H] poles and two 16 1/4" [I] poles.

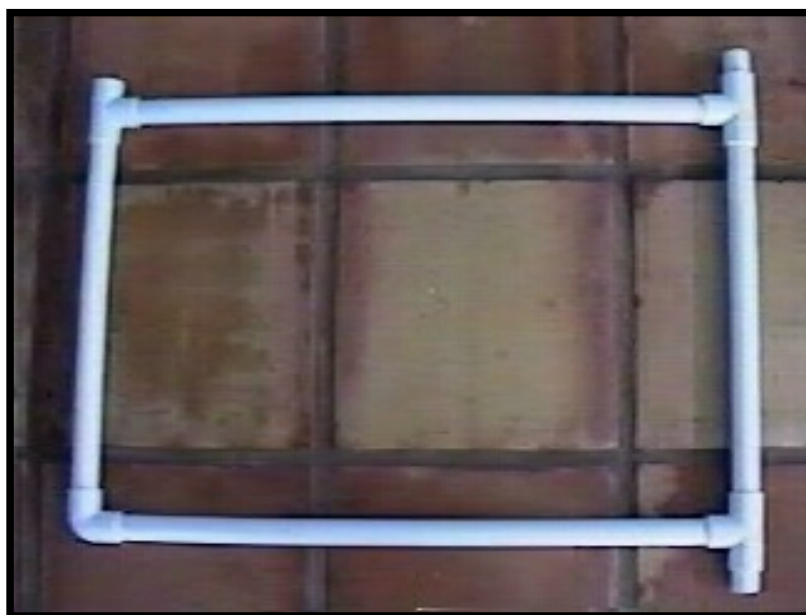

Assemble with three T connectors and one corner.

Cut two [E] pvc sections and put them in as shown: top and bottom.

The short sections sticking out of the two T connectors are going to be hinges.

To make them work well, you need to

'slot' them.

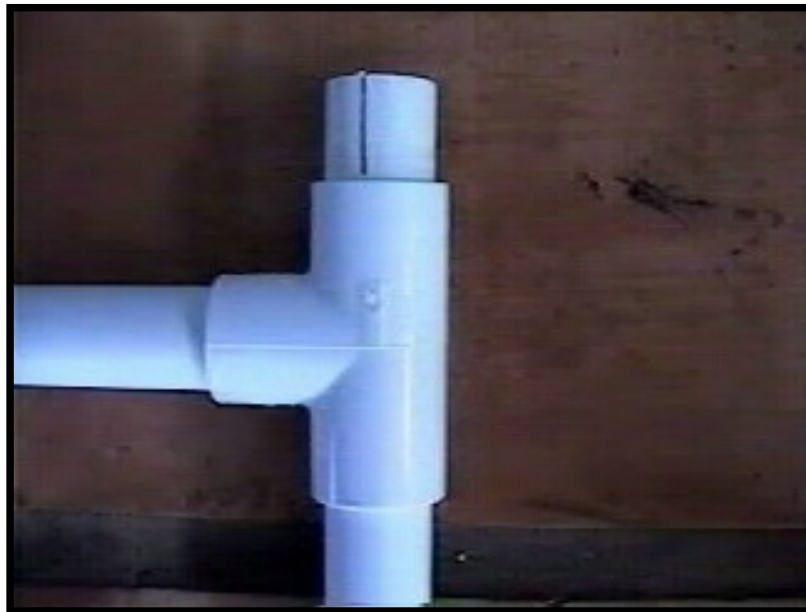

A jig saw works well to cut the slots. Be careful!



Set the whole assembly in the door frame and put a T connector on the top right side, connecting it to the cage frame.

See how nice those hinges work now?

(Just ignore that the cage in these pictures is the Big Jungle Gym... It's the exact same door on both cages).



For the left side, cut a 22 1/2" [C] pole and top it with a T connector.

Next, cut a 5" [J] pole and put it into the door on the left side top.



You can congratulate yourself now, because if you made it this far...

the rest will be pretty easy.

The top of the door is just like the bottom - except bigger and upside down.



Cut two 24 3/4" [H] poles and two 35 1/2" [K] poles.

Assemble with three T connectors and one corner connector.

Insert the two 1 1/2" [E] sections of pvc into the two right-side T's, and slot them.



Add this top section to the cage door.

(Again this is the Big Jungle Gym but the doors are the same)

Cut another [B] pole for the left hand side of the cage door frame.

Push and pull the pvc until the door fits nicely. Not bad!

Just one more tricky little thing to do...

Those wide gaps above and below the door have to be filled.

Cut two 25 3/4" [L] pvc poles and put the Oversized T connectors on the ends. (These are the 1" x 1" x 3/4" T connectors).



Now here's the tricky part:

Use a jig saw to cut each T connector in half and trim their edges so they fit in the gap.

Cable tie the top one in place, so it doesn't fall out when you open the door!

If you don't have any long cable-ties, just 'daisy-chain' two together.

Notice the 3" [M] bolt and nut now added to



**keep the
door
securely
shut.**

**Another bolt
is
positioned a
similar
distance
from the
bottom.**

[Contents](#)

An Awesome Door

If you really want to go the extra mile and make an awesome door here's how...

**Use the
same
techniques
you just
used and
make a
small
hinged
door to fit
within the
lower
opening of
the large
door.**

**Start by
taking that
original
right side
16 1/4" [I]**

**pole out
and
topping it
with
another T
connector
with a
slotted plug.**

**Then
shorten the
pole (cut it
to size: 10
1/4" [N]) so
that
another T
and slotted
plug will fit
on the
bottom.**



**Add two 23
1/2" [O]
poles
horizontally
and
another 10
1/4" [N]
pole,
connect
with two 90
degree
corner
connectors,
and adjust
everything
for a nice
snug fit.**

**Use velcro
loops to
hold the
lower door
shut, or**

just drill for a longer bolt - 4 1/2" [P].

Cut four more 1" x 1" x 3/4" Ts in half and make two more gap-filling poles, using two 24 1/2" [Q] poles.

Cable tie in a mesh rectangle -- and you've got a safe and easy way to get food in and out of the cage, no matter what mood your iguana is in!

Now that's a great door!

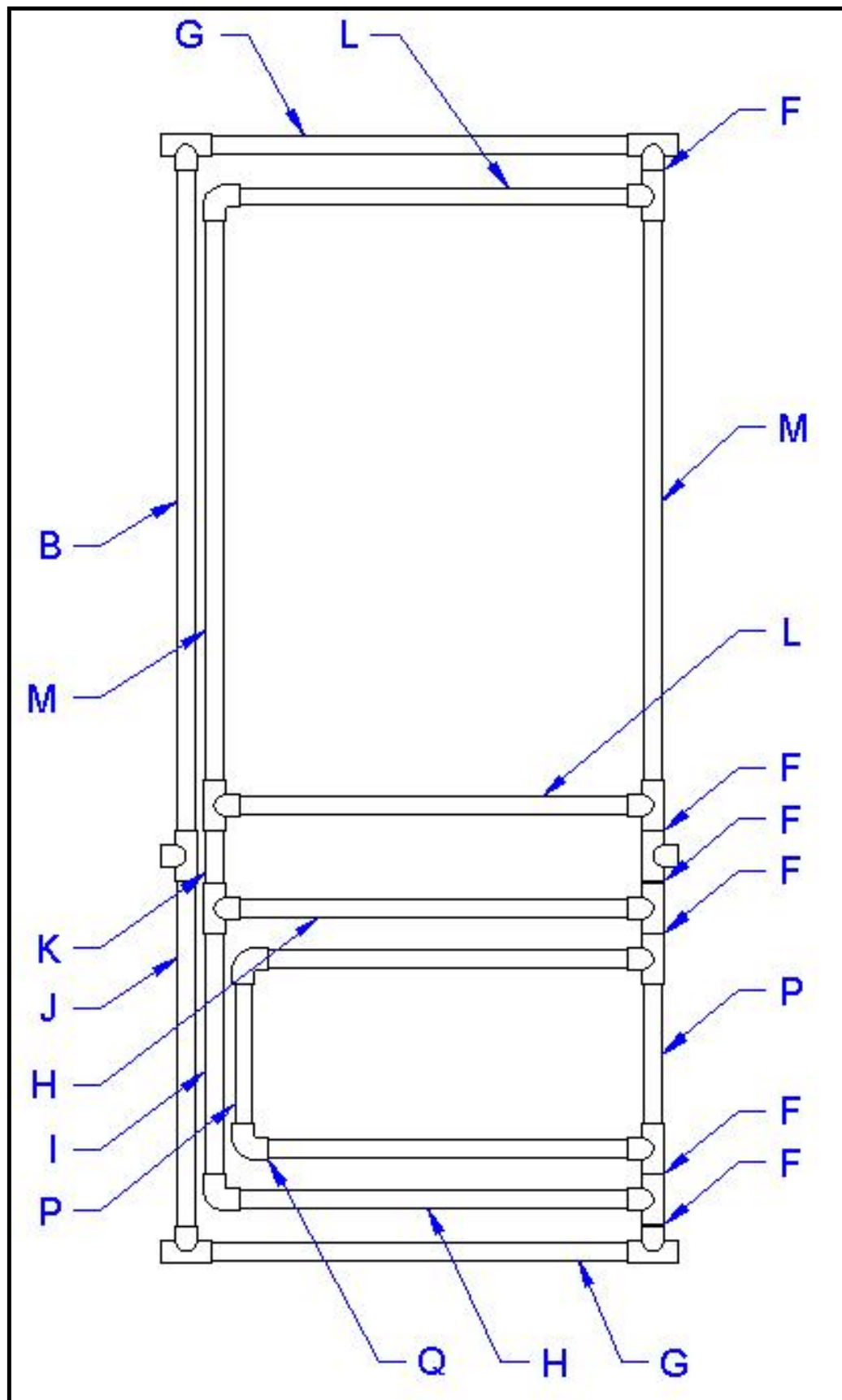

Now we've done the [frame](#), and the [door](#), so next let's do the [ceiling](#), and then the [back panels](#).

Once we've finish the [windows](#) and the [Basking Hammock](#), we're done!

[Contents](#)

Building the Mini Jungle Gym Ceiling

The ceiling isn't so hard to make - and it looks and works great!



At Home Depot, in the paneling department, are 4 x 8 sheets of melamine about 1/8" thick. Some of this 'Tile Board' is plain white, and some of the panels have designs on them.



Choose the style that you like best.

Have Home Depot cut a rectangle that measures 43" x 25" [R].

Cut off the four corners to match the frame shape.

Tip:

Cut

from

the

shiny

side

and

then

sand

the

edge

smooth.

**Now it's time
to lay out the
chrome trim
rings...**

**I like to use
two chrome
rings spaced
[S] in from
three of the
edges.**

**Make sure that
you leave
room for a
UVb light
fixture toward
the front.**

**Take the two
trim rings and
lay them out
on the shiny
side.**

**Use a marker
to trace the
inside circle of
each trim ring.
While your
ring is still in
place, mark**

**North South
East and West
just outside
the ring --
which will be
where you drill
holes for the
cable ties that
hold the rings
in place.**



**Drill a starter
hole just
outside the
circle trace
and use a jig
saw to cut a
circle 1/2"
outside of the
traced circle --
that's about
halfway
between the
circle trace
and the hole
marks.**



**The circle cut
doesn't have
to be a perfect
circle --
because it's
going to be
hidden by the
trim rings.**

Use a drill bit that is just slightly larger than your cable-ties to drill four holes, positioning the holes just outside of the edge of the trim ring: N S E & West.



Okay, now flip the ceiling over and cut a strip of uncoated wire cloth a little oversized [T].

Or you can cover the holes individually, like I did here:



To get the chrome ring in place: slide the ring underneath, lining it up so that you can see one of the four holes.

Poke the cable tie down

through the screen and back up through the hole, and tighten.

Tip:
Hang the panel and hole half way over the edge of the table to hold the ring in place while you tie it in.



The objective is to leave the cable tie 'squares' on top -- to help keep the dome lights in place.

In fact, when you clip the ends of the cable ties, leave a little extra sticking up as shown.

Okay, now flip the ceiling back over and drill a few holes 1/2" in from the outside edge to allow you to cable tie the ceiling to the cage.

I'd suggest putting the ceiling on top of the cage and marking for the holes first.

I like to place the holes in the corners and several next to the T connectors.

.....

Now we've done the [frame](#), the [door](#), and the [ceiling](#), but we still have to do the [back panels](#), the [windows](#), and the hanging shelf!

[Contents](#)

Building the Mini Jungle Gym back panels

The back panels are pretty easy - especially if you have Home Depot pre-cut the pieces for you!

The full size of this back panel is 33" x 68" [U].

Drill from the shiny side to make holes approximately every 6" to 12", (which are for cable ties to attach the panel to the cage frame.)

Drill a few more right down the center to hold



**the panel
securely
against the
cage frame.
Just mark and
drill pairs of
holes -- from
the inside of
the cage.**

**The corners
are a little
trickier, but
not too
much:**

**As you can
see, the holes
are drilled so
that they line
up with each
other.**



**The narrow
corner upper
panels are
6 1/2" x
43" [V].
The narrow
corner lower
panels are
6 1/2" x
24" [W].**

**You'll need
four of each
for the whole
cage.**

**That covers
the rear
corners and
the two front
corners.**

A nice alternate option is to cut those front corner pieces from clear Lucite.

The best way I've found to join the corners is to notch them.

I use a template:

The dimensions of this template are:

6 1/2" [X] wide, with notches.

To make the notches: mark 3/4" down from the top edges, cut 1 1/2" in from the side edges, and cut back to the top edge with a 1/2" slope.

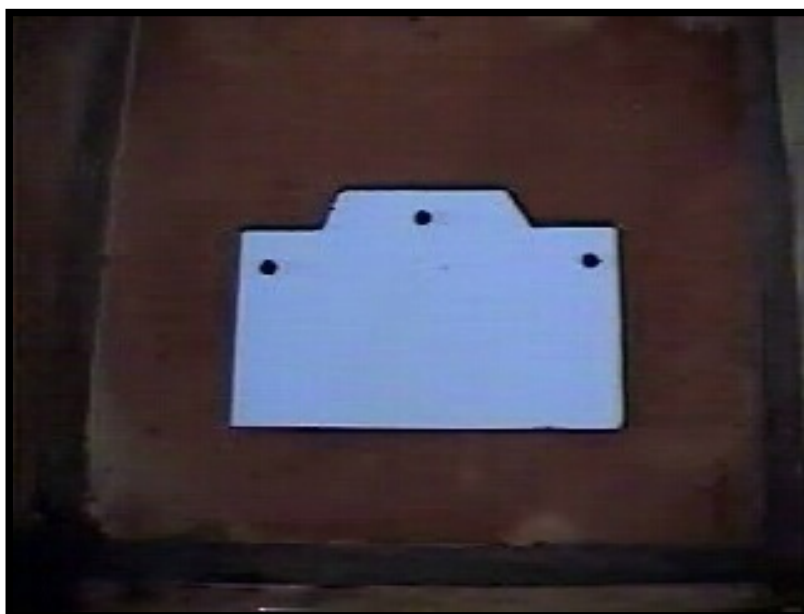

Another alternate option for the front is two mesh inserts...

I use 1" green plastic mesh (8 1/2" wide) and lash it to bamboo poles (68" tall) using jute twine and a locking stitch - and then cable tie the bamboo poles to the cage frame.



But this a lot of extra work, when all you really need to do is to cut more white melamine paneling or clear Lucite.

Or simply cable-tie green mesh into place around the door.



I like to think that these mesh panels improve the

**interaction -
and quality of
life - of the
cage
inhabitant.**

**The only
other
melamine
pieces you
need now are
for the lower
sides under
the windows.**

**Cut two
panels [Y]
and drill holes
that line up
with the holes
in the lower
corner panels.**

**Remember to
drill from the
shiny side.
Now you can
see why I add
the bamboo
trim.**

**The outside
of this
melamine
paneling is
just plain
brown.**

**Another
option would
be to paint
the outside of
the panels...
maybe even**



the same
color as the
room they'll
be in?

Or use some
of that
bamboo
screen
material to
trim the
exterior.

Now that's a
nice look!

.....

Now we've done the [frame](#), [the door](#), [the ceiling](#), and the [back panels](#).

Once we do [the windows](#) and the [Basking Hammock](#), we're done!

[Contents](#)

Adding Windows to the Mini Jungle Gym

If you start with two sheets of 32" x 44" [Z] Lucite (or a similar acrylic), you can simply lay the sheets directly on the side panels, lining up the sheet with the center of each pvc pole, and use a marker and a straight-edge to draw cut lines.



You'll be able to get two side windows out of the one sheet.

The other sheet will yield the window portion of the front door...



And you'll have a 6" piece left over that would be

perfect for
one of the
front
corners!

To cut the
Lucite, I
prefer to use
an orbital jig
saw with
very sharp
blades
although
people tell
me that
scoring both
sides deeply
and
snapping
gives a nice
clean edge.

The
dimensions
of each side
window is
15 1/4" x 43
3/4" [AA]
and the
front door
window is
26" x
44" [BB].

Use a sharp
drill bit to
make holes
about a half
an inch in
from the
edges.

I like to
space them
out to match
the holes in

**the white
side panels,
so that I can
use just one
cable tie --
through
both holes
and around
the pole.**

**Just hold
the side
window up
to the frame
and mark
where the
holes need
to be to
match up
with the side
panel holes.
Then drill,
against a
piece of
scrap wood
to avoid
cracking the
Lucite.**

**Make sure
that the
cable tie
square ends
are flat
against the
Lucite and
clip the
excess.**

The side window panels are attached to the *outside* of the cage frame, just like the white back panels -- lining up all the holes.

The door window panel, however, is attached to the *inside* of the door frame, so that you have the poles accessible to grasp, to open the door, as well as having access to the bolts that keep the doors shut.

Tip:

Take the protective plastic off the Lucite *before* attaching it to the cage frame.

Another tip:

If the cut edges of the Lucite present any dangerously sharp edges, you can use white cloth tape to cover the edges all around, nice and neatly, before you attach the lucite windows to the frame.

Now we've done [the frame](#) and [the front door](#) and [the ceiling](#) and [the back panels](#) and [the windows](#).

Now all we've got left to do is [the basking shelf](#), which will be the lizard's favorite spot!

.....

[Contents](#)

Building the Basking Hammock and Shelves

These shelves are my favorite part of the cage to build -- and they add so much style and function -- I just love 'em.

If you read my web page on the history of my cage-building endeavors, you know that I used to build my corner cages completely out of real bamboo.

However, practical considerations have eliminated almost all of the real bamboo from my cages now.

The only bamboo you need for this project is what Home Depot sells as 'Natural Reed Fencing'.

It comes in 6'x 15' rolls for under \$20.



You'll have plenty for the shelves, and enough left over to add some beautiful trim to your new enclosure.

(Home Depot will transfer a roll to your local HD store, if you ask. Florida HD stores carry this year 'round.)

If you're making this cage-building project a family affair, you can get someone started on making these shelves right off the bat.

Let's start with the corner shelves... These shelves fit well in either cage: the Mini Jungle Gym or the Big Jungle Gym.

For the Mini Jungle Gym, a

nice option is to use six corner shelves...



The measurements are:

- (1) 26" pvc pole for the front
- (2) 19" pvc poles for the sides.

Assemble as shown with two 45 degree angle connectors joined in the rear corner, and one 90 degree connector joined with a 45 degree connector on each side.

Use three 1 3/4" pvc

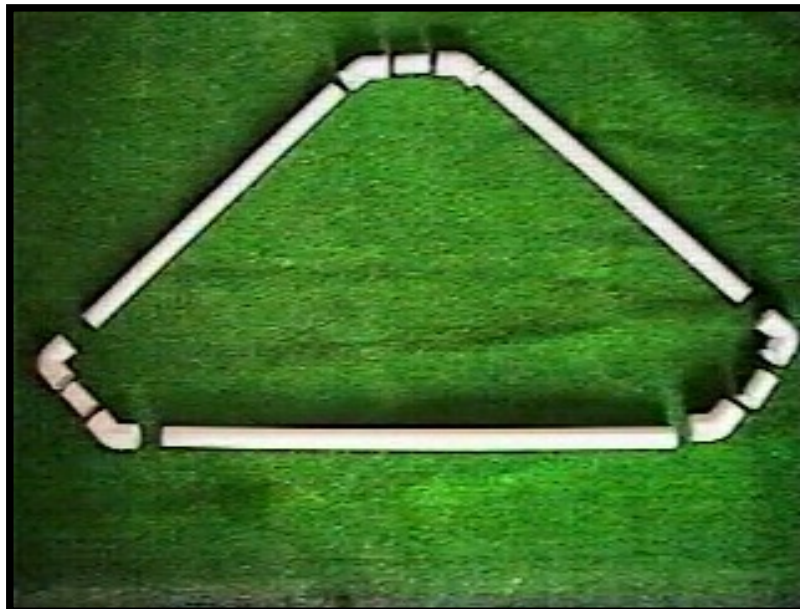

sections to
join the
connectors.

Next, cut a
piece of
plastic mesh
to fit the frame.

To keep the
mesh from
rolling, I attach
it with a
couple of ties,
while I cut it
down the
center of the
pvc poles.

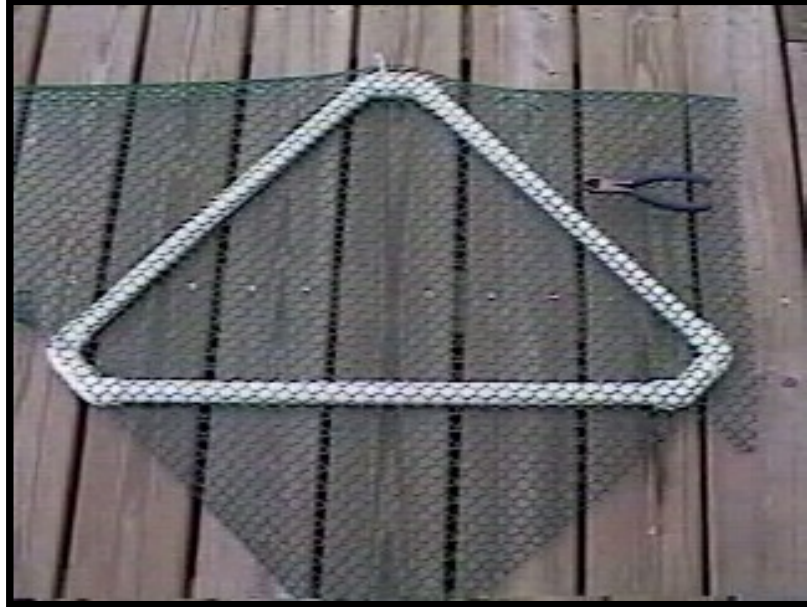

Once the
mesh is cut to
size, attach it
to the frame
with ties every
4 or 5 inches.
Clip the
excess tail
ends from the
ties.



Using 3/4 pipe insulation, cover the frame.



This adds thickness to the shelves, as well as helping keep the bamboo in place (from spinning when climbed on) on the lower shelves - the ones without floors.

The bamboo has been cut into 7" wide strips and then had the outer two bamboo sticks removed so that the remaining wire can be twisted together and folded under.



The 6 1/2" bamboo strips can be cut to size with strong scissors.

Use 11" black cable ties over the bamboo.

Pull the ties tight with pliers so that the tails are underneath the shelf and clip the tails off.



Make four more of these, omitting the floor. For the chains, make 17 sections of 9 links each to connect each shelf.

The bottom shelf only gets two chain lengths -- up front.

Attach single, open links to the cage frame top with cable-ties, then just lift the stack of shelves into the cage and hang them from the open links.

This allows you to easily install or remove the shelves, just by lifting them off of the open links cable-tied to the cage frame.

Use the same 'open link' technique at the floor level to stretch the shelves across the cage so that they cascade down under the Basking Hammock.



This allows you to unhook the shelves and let them just hang straight down in the enclosure, giving you room to step into the cage for cleaning or spending a little quality time with your iguana.

To make the Basking Hammock, just use the same techniques with these measurements:

Cut (2) 30" pvc poles
and (2) 15"
pvc poles.

Assemble with four 90 degree corner connectors.

Add the mesh floor, pipe insulation and bamboo, all held together with cable ties.

Attach chains with 10 or 11 links to the rear corners.

I like to use several extra links in the front chains to create a slight forward angle.

Using the 'open top link' method to hang the shelves also allows you to adjust how close the shelves are to the lights.



**No matter what cage you build,
the shelves will be your iguana's favorite spot!**

.....

Although a floor would be nice...

I've got a few different ways to handle that project...

[Contents](#)

Cage Floor Alternatives

One easy floor idea is to use a 4 x 4 square of linoleum (or smaller for the Mini Jungle Gym).

And -- it's easy to sponge clean.

A more ambitious project is to make a small deck platform, about 8" high out of 2x8 boards in the shape of the cage, cover it with a piece of tile board (you'll have one 4x4 piece left over from cutting the ceiling piece from a 4x8 sheet). Then make a cut-out for a tub - like the large black cement mixing tubs at Home Depot that sell for \$13 each or the medium size tub for \$6.

Here's one example:

This picture shows a raised mesh floor on the Big Jungle gym frame.

Those two mesh panels let all the mess fall through - keeping the cage clean inside.

The front panel lifts up... to step inside.

Those sliders make it easier to pull the cage out from the corner... to clean underneath.

With the dome lights on top, this enclosure is now 7



1/2 feet tall!

My best floor idea involves using pvc and plastic mesh. The pvc and a handful of 4-way cross connectors and right angle connectors are employed to create a raised base about 10" high - with pvc poles that acts as skids to slide the cage forward and back.

Two floor panels are then made to fit the shape of the floor and plastic mesh is cable-tied to them to create a floor which is then suspended about 8" above the cage floor, leaving room for a tub under the cage.

By securing one panel to the cage frame with cable ties, and the other panel to that one - it works like a trap door - allowing you to lift the floor panel up and step inside the enclosure - or allow access to the tub.

It also works like a trampoline for the lizard, which is nice for when the lizard wants to go crazy, but the best thing is that it keeps the lizard from 'poop-painting', because everything just drops through to the newspaper on a tarp down below. It also adds more height to the enclosure, which is a good thing.

The most attractive floors that I've been shipping have been dark green astroturf cut a little oversized in the shape of the floor. However, the astroturf gets dirty quickly, and it's possible to pull pieces of it off from the edges - creating an 'impaction' hazard if ingested.

I suggest only using those floors like you would a table cloth for the dining room table: only for when guests are coming over. And maybe tape the edges with cloth tape.

Many people just use newspapers over a tarp in the bottom of the floorless cage. I suggest using a piece of thick carpeting or a pad under the tarp to soften the blow of any free-falling done from the basking hammock.

Above all - have Fun!

[Contents](#)

[Main Index](#)

©Iguana.reptile-cage-plans.com reproduced with permission from lizardcages.com

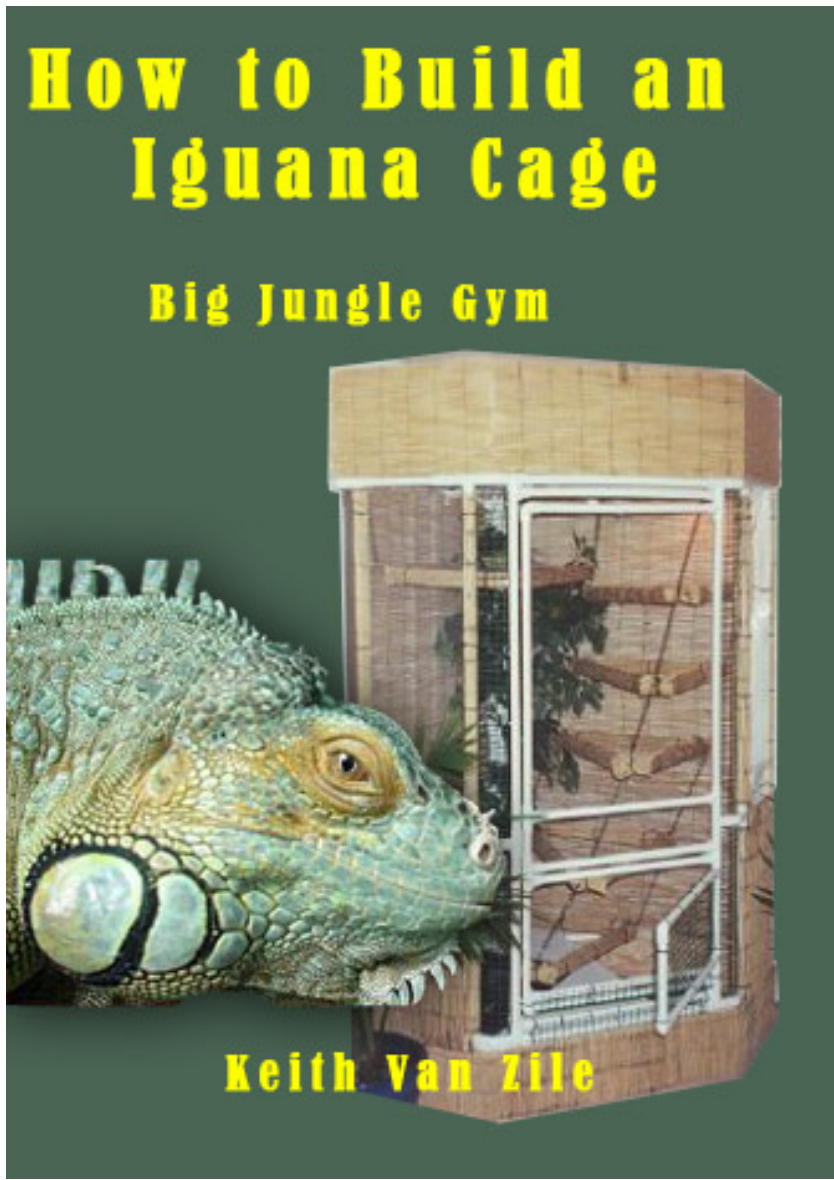

[Main Index](#)

Big Jungle Gym

Contents

[Introduction](#)

[Materials & Measurements List](#)

[Tools](#)

[Measurements](#)

[Shopping List](#)

[Building the Big Jungle Gym](#)

[The Frame](#)

[The Door](#)

[The Ceiling](#)

[Back Panels](#)

[Windows](#)

[Basking Hammock and Shelves](#)

[Floor Alternatives](#)

Introduction

These plans have been compiled from material supplied with permission from Keith Van Zile. They are intended as a guide to creating cages suitable for Iguanas, chameleons and a range of other animals. As with any captive animal it is the responsibility of the owner to create the best possible habitat and conditions for the animals within their care.

Considerable time and expense has gone into creating these plans.

For best results it is recommended that you read through the plans in their entirety before starting to construct the cages.

If you become frustrated or have difficulties, walk away for about 30 min and do something else. Many times when you come back to a difficulty, you will be rewarded with a solution, or at least a better frame of mind.

Have fun with these plans and enjoy your time building something you will be proud of.

[Contents](#)

Materials & Measurements List

Tools

Here are the tools you'll need:

(1) pvc cutting tool. For hand tools, I like the Ridge Tool Company unit (about \$14), but some people like the tool that looks more like a pruning shear for pvc. They both work well.

I'd avoid attempting to cut all the pvc with a hack saw -- you'll wear yourself out! A jig saw works fine for cutting the pvc, too.

(1) Orbital Jig Saw (about \$29 at Kmart) (1) measuring tape (1) pair clipping pliers (1) sanding block (1) drill (1) straight-edge (1) pair strong scissors

Measurements (coordinated with the plans):

Each of the lettered pieces below corresponds with a piece in the plan. Do not worry about this too much at this stage. The plans will have each of these with the correct measurement in the appropriate place. These are used when designing the original plans.

[A] 20
[B] 41 1/2"
[C] 22 1/2"
[D] 13 3/4"
[E] 4 1/2"
[F] 1 1/2"
[G] 26"
[H] 24 3/4"
[I] 16 1/4"
[J] 22"
[K] 5"
[L] 24 3/4"
[M] 35 1/2"
[N] 25 3/4"
[O] 3"
[P] 10 1/4"
[Q] 23 1/2"
[R] 4 1/2"
[S] 24 1/2"
[T] 10" x 36"
[U] 47"

[V] 37" x 68"
[W] 6 1/2" x 43"
[X] 6 1/2" x 24"
[Y] 16" x 25"
[Z] 32" x 44"
[AA] 15 1/4" x 43 3/4"
[BB] 26" x 44"

Materials: (approx. total cost: \$175)

[Contents](#)

3/4" PVC Poles: (~\$10)

Home Depot and Lowes sell them in 10' lengths. You'll need 20, but I'd suggest getting 25, so you have a few extra for shelves and mistakes. They're only about .77 cents each at Lowes. If you have a choice between thicker or thinner poles, I suggest using the thinner ones, known as 'Class 200'. The thinner ones still provide plenty of cage strength since the panel-based design provides a lot of structural support.

(12) 4-way cross T connectors 3/4" (known as: "4 way cross")
(16) 90 degree angle connectors 3/4" (corners) (14 are for shelves). (2) 3/4" caps (4) T connectors - marked: 1" x 1" x 3/4" (these are for around the door. A jig saw will be required to cut them in half. You can see how in the online plans and pictures.) If you intend to make the door-within-a-door, get 4 more of these oversized Ts, plus (2) more corners and (2) more regular 3/4" Ts.

Tip: Masking tape is a handy way to hold the bundle of poles together to transport them at the store.

3/4" PVC Pipe Connectors: These are all the T connectors and Elbows and Angles that you'll find in the plumbing department at Home Depot.

Here's what you'll need:

Number	Part
42	T connectors (these are all for 3/4" pvc)
50	45 degree angle connectors 3/4" (20 are for the corner shelves)
12	4-way T connectors 3/4" (known as: "4 way cross")
16	90 degree angle connectors 3/4" (corners) ((14 are for shelves).).
2	3/4" (corners) ((14 are for shelves).).
4	T connectors - marked: 1" x 1" x 3/4" (these are for around the door. A jig saw will be required to cut them in half. You can see how in the plans and pictures.) If you intend to make the door-within-a-door, get 4 more of these oversized Ts, plus (2) more corners and (2) more regular 3/4" Ts.

[Contents](#)

Paneling

For the back panels, I use shiny white 1/8" paneling. This 'White Tile Board', is sold in 4x8 sheets, (1/8" thick) for about \$10 per sheet at most Home Depots.

Tip: Home Depot will cut the panels to size FOR you, if you ask. It comes in different designs, too, if you prefer something other than plain white.

It comes in different designs, too, if you prefer something other than plain white.

You'll need three sheets. Unless you have a truck or van to transport them, I suggest going in with the dimensions and having them (Home Depot or Lowes) cut it for you.

The dimensions of the white paneling are: (1) 48" x 48" -- for the ceiling. (2) 68" x 37" -- for the back panels. (2) 24 3/4" x 16" -- for the lower front side panels - under the windows. (3) 43" x 6 1/2" -- for the upper corners. (3) 24" x 6 1/2" -- for the lower corners.

How they want to get these dimensions out of the three 4 x 8 sheets is up to them.

TIP: I usually sketch it out on a piece of paper first - just to make it easy for them.

Most of my ceilings are actually 46 1/2" x 46 1/2" once I've trimmed them to size. You'll probably have a 4x4 square left over from the three sheets of paneling -- you could save it to become used as a floor, or have it cut into narrow panels for around the door.

The narrow panels on the right and left side of the door are: (2) 5 1/4" x 41 3/4" - no notches are necessary. (2) 5 1/4" x 22 1/2" - no notches. (You can use clear lucite or these white panels - or even plastic mesh lashed to real bamboo poles with twine here - my favorite choice).

Windows

For the clear front door window and two side windows, I buy two Lucite panels in sheets of 32" x 44" for about \$13 each. Cut in half, one sheet yields two side windows.

Front door

For the front door, one Lucite panel covers the top two thirds of the door, and a door-within-a door is a handy bottom addition -

although an easy alternative option is to get one sheet of Lucite 72" x 36" (for about \$36) and make the whole door clear, instead of making the lower door-within-a-door.

If you use a 32" x 44" sheet, just cut a 6" piece off the long way, and drill holes for cable ties in the corners and every 12" or so, 1/2" in from the edge. An orbital jig saw is the easiest method I've found to cut the Lucite, although you can also score both sides deeply and snap a clean line - if you're lucky.

A sharp drill bit used slowly and very carefully makes clean holes.

TIP: I recommend drilling through the Lucite into a piece of scrap wood underneath to avoid cracking the Lucite. I've found that the least expensive acrylic (Lucite) panels work fine as windows.

One roll of 3' x 5' plastic mesh will give you enough for the two top shelves -- from the Landscaping dept. at Home Depot.

If you want to line the whole cage with mesh as shown with the Basking Cage, Home Depot has 1" mesh in 25' x 40" rolls for about \$9 each. You'd need two rolls to line the entire cage. 6' bamboo stakes are a handy way to hold the mesh to the frame using cable ties.

If your lizard is small, I suggest using the dark green 1/2" plastic mesh. from Lowes. Either one cuts easily with strong scissors or cutting pliers (clippers).

Cable Ties

(1) bag of white cable ties at least 7.5" long. Qty: at least 200.
(Electrical Dept.)

I also use the 11" black cable ties (Qty: 100) to hold the bamboo on the shelves, which are covered in 3/4" pipe insulation (those long black tubes - you'll need (5) 6' lengths of them - marked 'For 3/4" copper pipe'). They give the shelves some thickness under the bamboo.

TIP: When you clip the tail off of the cable ties once they're in place, pull on the tail end hard while clipping it, so that you don't leave a sharp edge. The remaining tail snaps back into the cable tie square - giving it a "smooth shave".

Ceiling

The ceiling takes 4 chrome rings (under \$5 each) which are actually stove trim rings: 8" trim rings from GE. Part number: PM31X105. At Home Depot. Recessed lighting trim rings also work well, if you'd prefer those.

You'll also need a 2' x 4' roll of un-coated wire cloth, if you'd like a barrier between your lights and the cage. 1/4" works well, although smaller gauges like 1/8" are even easier to work with. You'll need one 10" x 38" swath and one 10" x 10" piece of the wire cloth for your ceiling. You'll see from the ceiling plans how it is used as a barrier to keep the lizard from the lights. Cuts easily with strong scissors.

Mesh and Bamboo for Climbing Sections

If you can't find a roll of bamboo 'Natural Reed Fencing', you can use any suitable alternative, such as the matchstick blinds or bamboo mats from Pier One, or even some brown indoor/outdoor carpeting.

A 4x6 matchstick blind gives you enough material to cover all 6 shelves. If you can find the bamboo fence material - it cuts relatively easily with strong scissors or tin snips.

Home Depot can transfer a roll to your local store from a store that stocks it, for example: from almost any Home Depot in Florida. Lowes has it too: item #147448.

Chains

You'll also need chains. Home Depot and Lowes will cut the Black Decorative chain to length for you. Get 23 feet. It runs about \$.60/ft.

For the front door, get two narrow 3" bolts with nuts.

For convenience, you may want to attach small cords to them with twine and tie them to the cage, so that they don't get lost.

If you opt to make a lower door-within-a-door, get one 4 1/2" bolts instead or use 9" loops of double-sided velcro. Nuts aren't really necessary - the bolts are sufficient to pin the door closed.

[Contents](#)

Shopping List for Big Jungle Gym

Tools:

_____ (1) pvc hand-cutting tool - or -

_____ (1) Jig Saw

_____ (1) measuring tape

_____ (1) Wire clippers

_____ (1) Drill

Materials: (approx total cost: \$225 + tax)

_____ (25) 3/4" pvc poles (\$20)

_____ (42) T connectors for 3/4" pvc (\$10)

_____ (50) 45 degree angle pvc connectors 3/4" (\$15)

_____ (12) 4-way cross T pvc connectors 3/4" (\$20)

_____ (16) 90 degree angle pvc connectors 3/4" (\$4)

_____ (2) 3/4" pvc caps

_____ (4) 1" x 1" x 3/4" T pvc connectors - or (8) if making lower door, too, plus (2) more 90 degree corners and (2) more 3/4" Ts. (\$10)

_____ (3) 4' x 8' sheets of 1/8" White Tile Board: (\$30)

Cut to:

(1) 48" x 48"-for the ceiling.

(2) 68" x 37"-for the back panels.

(2) 24 3/4" x 16"-for the lower side front panels.

(3) 43" x 6 1/2"-for the upper corners.

(3) 24" x 6 1/2"-for the lower corners.

(+1) 4' x 4' section left over for floor

_____ (2) 32" x 44" Lucite panels (\$30)

_____ (1) roll green landscaping plastic mesh (\$9)

_____ (1) 200 ct. bag of 7.5" white cable ties (\$6)

_____ (1) 100 ct. bag of 11" black cable ties (\$6)

_____ (4) 8" chrome stove trim rings, pn#: GE PM31X105 (\$20)

_____ (1) 2' x 4' roll, 1/4" un-coated wire cloth. (\$4)

_____ (5) 6' lengths for 3/4" copper pipe foam insulation (\$6)

_____ (1) roll, bamboo 'Natural Reed Fencing' 6' x 15' (\$20)

Item # 325-538 at Home Depot.

OR: matchstick blinds, bamboo mats, or brown indoor/outdoor carpet.

_____ (1) 23' length, black decorative chain (\$15)

_____ (2) narrow 3" bolts, (with nuts) for door, (+1) 4 1/2" bolt if you make the smaller door-within-a-door.

[Contents](#)

Building the Big Jungle Gym

The dimensions of this enclosure are: 5.5 feet wide, 4 feet deep and 5.75 feet tall.



The Frame

For this enclosure, you'll need 20 [A] pvc poles.

Cut 3/4" pvc into 2 lengths of 41 1/2" [B] and two lengths of 22 1/2" [C] and 3 lengths of 13 3/4" [D].



The connectors are two Ts on top two Ts on the bottom and two 4-way crosses in the middle.



The trick to putting them together is to twist them in.

PVC can be pushed into a connector up to 3/4", but I would suggest going in only 1/2" for now. You can always tighten and straighten it up later - once everything is together.

The trick to that is to use your body weight to push the joints together.

After you have made six panels, your cage can start to take shape. Connect the panels to each other with



**corners
and
spacers.**

**Spacers
are just 4
1/2" [E]
lengths of
pvc that
connect
panels to
form the
back walls.**

**Corners
are just
two forty-
five degree
angle
connectors
joined by a
[F] length
of pvc with
two more
pvc plugs
in the ends.**

**You'll need
to make
nine sets
of corners
and six
spacers to
form your
cage.**

**Go ahead
and
connect all
the panels
now.**

**Here's the
shape**

**you're
looking for:**



[Contents](#)

Building the Big Jungle Gym Front Door

The Front Door is a truly great feature of these cages.

The working hinges are a real convenience, since you need to get in and out of your lizard's enclosure several times a day, and the lower second door is brilliant.

Okay, let's get started.

Did you notice that the six corners around the door are just single 45 degree connectors (with the 1 1/2" [F] pvc plugs on each side), unlike the doubled-up 45 degree connectors that form the three back corners? Go ahead and put those in, if you haven't already.



So, let's add the top and bottom of the door, to complete the cage frame shape.

Cut two 26" [G] pvc poles. Put the T connectors on the ends of each pole.



Go ahead and put them in to complete the frame shape.



Now it's time to get down to the door construction itself. Here's what it looks like completed... for reference.



Let's build from the bottom up. To make the lower section of the door: Cut two 24 3/4" [H] poles and two 16 1/4" [I] poles. Assemble with three T connectors and one corner.



(If you plan to build the lower door-within-a-door, you might want to skip down to the bottom of this page and read about how to do it.)

Cut two 1 1/2" [F] pvc sections and put them in as shown: top and bottom.

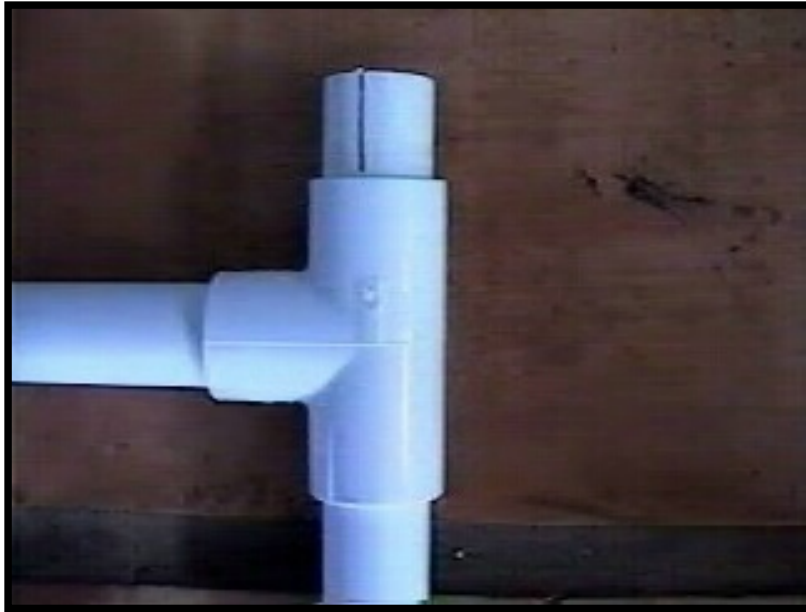

The short sections sticking out of the two T connectors are going to be hinges. To make them work well, you need to 'slot' them.

A jig saw works well to cut the slots.

Be careful!



Set the whole assembly in the door frame and put a T connector on the top right side, connecting it to the cage frame. See how nice those hinges work now?



For the left side, cut a 22" [J] pole and top it with a T connector.

(No notches required - the hinges are only on the right side).

Next, cut a 5" [K] pole and put it into the door on the left side top.



You can congratulate yourself now, because if you made it this far... the rest will be pretty easy.

The top of the door is just like the bottom - except bigger and upside down.



Cut two 24 3/4" [L] poles and two 35 1/2" [M] poles.

Assemble with three T connectors and one corner connector.

Insert the two 1 1/2" [F] sections of pvc into the two right-side T's, and slot them.

Add this top section to



**the cage
door.**

**Cut another
41 1/2" [B]
pole for the
left hand
side of the
cage door
frame. Push
and pull the
pvc until the
door fits
nicely. Not
bad!**



**Just one
more tricky
little thing to
do...**

**Those wide
gaps above
and below
the door
have to be
filled.**

**Cut two 25
3/4" [N] pvc
poles and
put the
Oversized T
connectors
on the ends.
(These are
1" x 1" x
3/4" T
connectors).**

**Now here's
the tricky
part:**

Use a jig

**saw to cut
each T
connector in
half and trim
their edges
so they fit in
the gap.**

**Cable tie the
top one in
place, so it
doesn't fall
out when
you open
the door! If
you don't
have any
long cable-
ties, just
'daisy-chain'
two together.**

**Notice the
3" [O] bolt
and nut now
added to
keep the
door
securely
shut.**

**Another bolt
is
positioned a
similar
distance
from the
bottom.**



[Contents](#)

An Awesome Door

If you really want to go the extra mile and make an awesome door here's how...

Use the same techniques you just used and make a small hinged door to fit within the lower opening of the large door.

Start by taking that original right side 16 1/4" [I] pole out and topping it with another T connector with a slotted plug.



Then shorten the pole (cut it to size: 10 1/4" [N]) so that another T and slotted plug will fit on the bottom.

Add two 23 1/2" [O] poles horizontally and another 10 1/4" [N] pole, connect with two 90 degree corner connectors, and adjust everything for a nice snug fit.

Use velcro loops to hold the lower door shut, or just drill for a longer bolt - 4 1/2" [P].

Cut four more 1" x 1" x 3/4" Ts in half and make two more gap-filling poles, using two 24 1/2" [Q] poles.

Cable tie in a mesh rectangle -- and you've

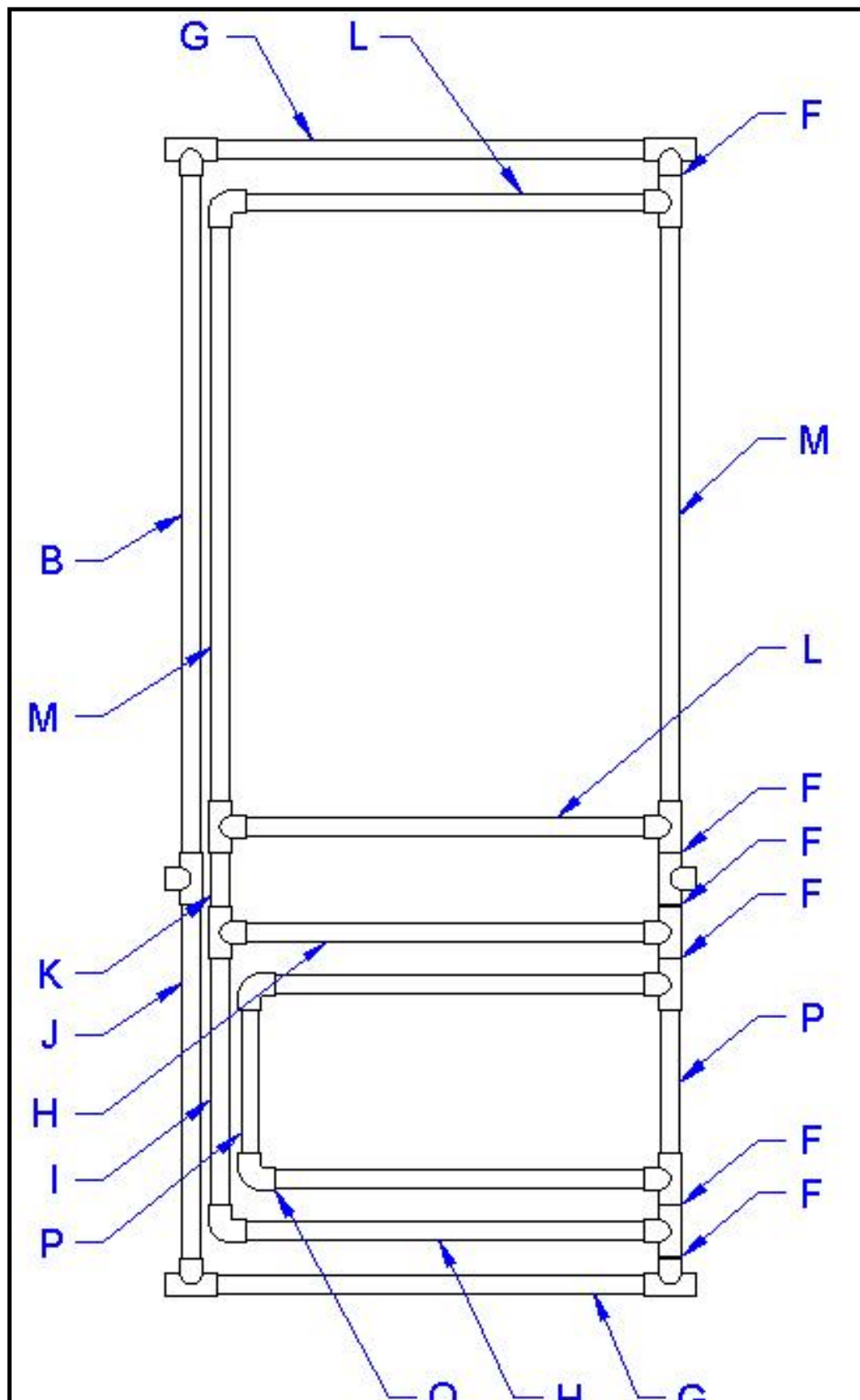

got a safe and easy way to get food in and out of the cage, no matter what mood your iguana is in!

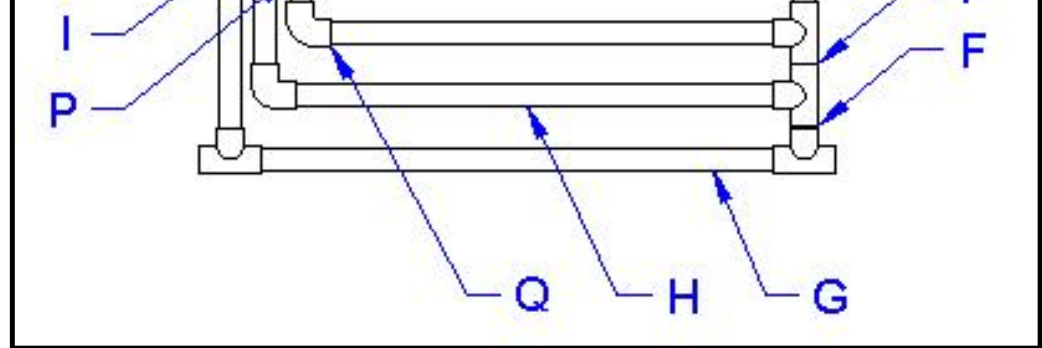

Now that's a great door!

Now we've done the [frame](#), and the [door](#), so next let's do the [ceiling](#), and then the [back panels](#).

Once we've finish the [windows](#) and the [Basking Hammock](#), we're done!

[Contents](#)

Building the Big Jungle Gym Ceiling

The ceiling isn't so hard to make - and it looks and works great!

I produce the ceiling in two panels, but only because I have to ship them out.

You don't need to cut your ceiling in half.



At Home Depot, in the paneling department, are sheets of melamine 1/8" thick. It's called 'Tile Board'.

If you went shopping with the Material List, you already have several of these 4 x 8 foot sheets, all cut up into the sizes you need. Having



**Home Depot
make the
cuts for you
is a huge
advantage!**

**For the
ceiling, it's
fairly simple:**

**Place the
4x4 sheet
on top of
the cage
and mark
along the
front door
edge.**

**Cut the front
corner off,
leaving you
with your
ceiling
shape.**

**Trim the
edges to fit
in the same
manner.**

Tip:

Cut from the shiny side and then sand the edge smooth.

While you're at it, cut off the three other corners, too.

Just measure 2 1/2" in from each corner, draw a line and cut off the tiny piece.



Now it's time to lay out the chrome trim rings...

You can use any layout you like. I like about 5 1/2" in from the edges.

Just make sure that you leave room for a UVb light fixture.



Take the four trim rings and lay them out on the shiny side.

Use a marker to trace the inside circle of each trim ring.

While your ring is still in place, mark North South East and West just outside the ring -- which will be where you drill holes for the cable ties that hold the rings in place.

Drill a starter hole just outside the circle trace and use a jig saw to cut a circle 1/2" outside of the traced circle -- that's about halfway between the



**circle trace
and the hole
marks.**

**The circle
cut doesn't
have to be a
perfect
circle --
because it's
going to be
hidden by
the trim ring.**

**Use a drill
bit that is
just slightly
larger than
your cable-
ties to drill
four holes,
positioning
the holes
just outside
of the edge
of the trim
ring: N, S, E
& West.**



**Okay, now
flip the
ceiling over
and cut a
strip of
uncoated
wire cloth a
little
oversized
10" x 36" [T].**

**(That's Tom,
by the way.**

He helped me build a few cages over the Summer.)



Now for the tricky part: slide a trim ring underneath, lining it up so that you can see one of the four holes.

Poke the cable tie down through the screen and back up through the hole, and tighten.

(Hanging the panel over the edge of the table helps.)



The objective is to leave the cable tie 'squares' on top to help hold the dome lights in place.

In fact, when you clip the ends of the cable ties, leave a little extra sticking up...

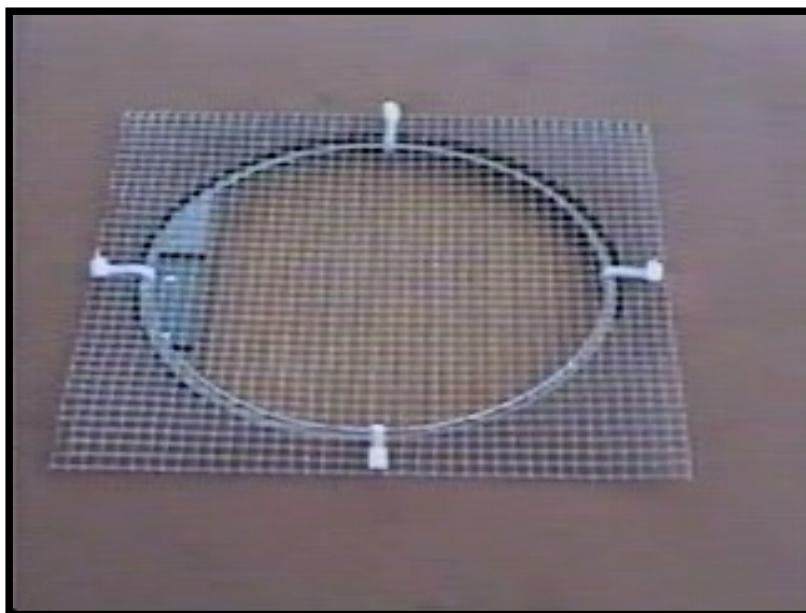

Okay, now flip the ceiling back over and drill a few holes 1/2" in from the outside edge -- to allow you to cable tie the ceiling to the cage.

I'd suggest putting the ceiling on top of the cage and marking for the holes first.

I like to place the



holes right next to the corners and T connectors.



One last thing, whether you cut your ceiling in half or not, it needs support...

Cut a pole 47" [U] and put the 3/4" caps on each end.



The support pole sits up on top of the cage and the ceiling is cable-tied to it.



That gives plenty of support for all the stuff on top: dome lights, a UVb fixture, and the timers plugged into powerstrips.

Timers, you say?
Definitely! In my experience -- iguanas like routine.

Having the lights go on and off at regular times is something that they will come to count on - whether you're there or not!

I suggest plugging four timers into two

**powerstrips
and set two
of the timers
for a '12 on
12 off' cycle
-- and
stagger the
other two.**

**Use four
timers for
the dome
lights and
plug a fifth
timer into
the open
slot of a
grounded
extension
cord (the
other two
slots are
taken by the
powerstrips)
and plug
your UVb
fixture into
that fifth
timer.**

**Pile
everything
up on the
cage
ceiling.**

**If you have
any more
open slots
on the
powerstrips
or extension
cord,
I'd suggest
keeping a
heating pad**

always-on
on the
basking
shelf.

By the way, those front mesh panels around the door could just as easily be clear Lucite panels...

I just prefer the 1" mesh panels for hand-feeding, clear viewing, and talking or listening to your lizard. I believe iguanas like listening to the environment around them as well.

For a smaller lizard, I'd suggest substituting 1/2" mesh for the 1" MultiNet.

If your home gets cold in the Winter -- better go with the solid front panels. You can save the mesh panels just for Summer use.

.....

Now we've done [the frame](#), [the door](#), and [the ceiling](#). We still have to do [the back panels](#), [the windows](#), and [the hanging shelves](#)!

[Contents](#)

Building the Big Jungle Gym back panel

The back panels are pretty easy - especially if you have Home Depot pre-cut the pieces for you!

I cut the large back panels into two pieces for easy shipping...

Although you can just pretend that the seam is not there.



The full size of this back panel (ignoring that seam) is 37" x 68" [V].

Drill from the shiny side to make holes approximately every 6" to 12", (which are for cable ties to attach the panel to the cage frame.)



The corners are a little

**trickier, but
not much:**

**As you can
see, the holes
are drilled so
that they line
up with each
other.**

**The narrow
corner upper
panels are: 6
1/2" x 43" [W].
The narrow
corner lower
panels are 6
1/2" x 24" [X].**

**You'll need
three of each
for the whole
cage. That
covers the
rear corner
and the two
side corners.**



**If you look
closely, you
can see the in
rear corner
where the two
pieces meet.**

The best way I've found to join those two pieces is to notch them.

I use a template:

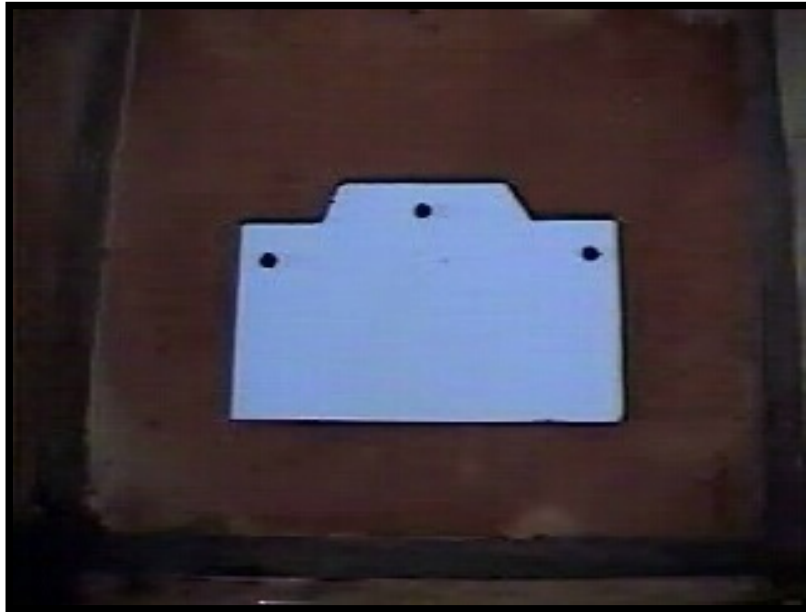

To make the notches: mark $\frac{3}{4}$ " down from the top edges, cut $1 \frac{1}{2}$ " in from the side edges, and cut back to the top edge with a $\frac{1}{2}$ " slope.

For the front two mesh inserts... I've been taking 1" green plastic mesh (5 $\frac{1}{2}$ " wide) and lashing it to bamboo poles (68" tall) using jute twine and a locking stitch.



But this a lot of extra work, when all you need to do is to cut and notch more white melamine paneling or clear Lucite. If you do, make these front panels slightly more narrow than the others: just 5 1/4" wide.



I just happen to think that these mesh panels improve the interaction - and quality of life - of the cage inhabitant.

Maybe you could just use them in the Summer...



The only other melamine pieces you need now are for the lower sides under the windows.

Cut two panels 16" x 25" [Y] and drill holes that line up with the holes in the lower corner panels.

Remember to drill from the shiny side.



Now you can see why I add the bamboo trim. The outside of this melamine paneling is just plain brown.

Isn't this better?



.....

Now we've done [the frame](#), [the door](#), [the ceiling](#) and the [back panels](#).

Now we'll do [the windows](#), and [the hanging shelves](#) and we're done.

[Contents](#)

Adding Windows to the Big Jungle Gym

If you start with two sheets of 32" x 44" [Z] Lucite (or a similar acrylic), you can simply lay the sheets directly on the side panels, lining up the sheet with the center of each pvc pole, and use a marker and a straight-edge to draw the cut lines.



You'll be able to get two side windows out of the one sheet. The other sheet will yield the window portion of the front door.

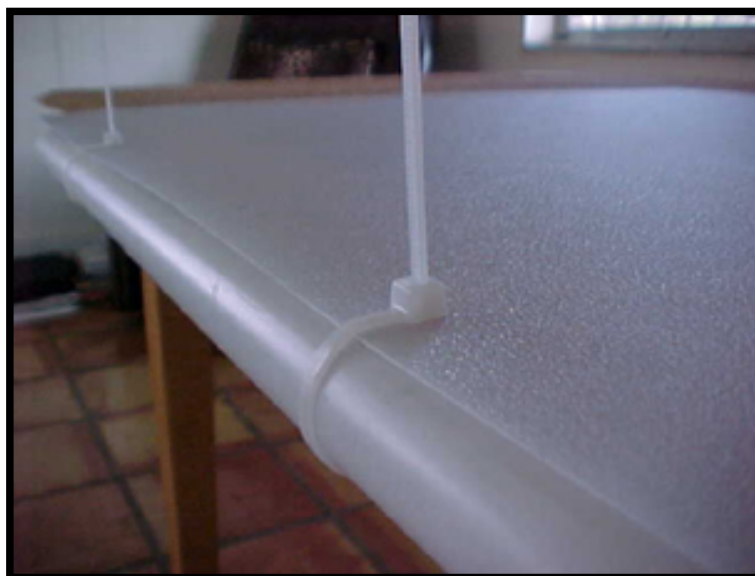

To cut the Lucite, I prefer an orbital jig saw with very sharp blades although people tell me that scoring both sides deeply and snapping gives a nice clean edge.

The dimensions of each side window is 15 1/4" x 43 3/4" [AA] and the front door window is 26" x 44" [BB].

I use a sharp drill bit to make holes about

**a half an
inch in from
the edges. I
like to space
them out to
match the
holes in the
white side
panels, so
that I can
use just one
cable tie --
through
both holes
and around
the pole,
just like we
did with the
back panels.**

**Just hold
the side
window up
to the frame
and mark
where the
holes need
to be to
match up
with the
back panel
holes.**

**Make sure
that the
cable tie
square ends
are flat
against the
Lucite and
clip the
excess.**

TIP:

Drill, against a piece of scrap wood to avoid cracking the Lucite.

The side window panels are attached to the *outside* of the cage frame, just like the white back panels -- lining up all the holes.

The door window panel, however, is attached to the *inside* of the door frame, so that you have the poles accessible to grasp, to open the door, as well as having access to the bolts that keep the door shut.

TIP:

Take the protective plastic off the Lucite *before* attaching it to the cage frame.

Another tip:

If the cut edges of the Lucite present any dangerously sharp edges, you can use thin white cloth tape to cover the edges all around, nice and neatly.

.....

Now we've done [the frame](#), [the door](#), [the ceiling](#) and the [back panels](#) and [the windows](#). Now all we've got left to do are [the hanging shelves](#), which are *really cool*, and then the [floor](#).

[Contents](#)

Building the Basking Hammock and Shelves

These shelves are my favorite part of the cage to build -- and they add so much style and function -- I just love 'em.

If you read my web page on the history of my cage-building endeavors, you know that I used to build my corner cages completely out of real bamboo.

However, practical considerations have eliminated almost all of the real bamboo from my cages now.

The only



bamboo you need for this project is what Home Depot sells as 'Natural Reed Fencing'.

It comes in 6'x 15' rolls for under \$20.

You'll have plenty for the shelves, and enough left over to add some beautiful trim to your new enclosure.

(Home Depot will transfer a roll to your local HD store, if you ask. Florida HD stores carry this year 'round.)

If you're making this cage-building project a family affair, you can get someone started on making these shelves right off the bat.

Let's start with the corner shelves...
These shelves fit well in either cage: the Mini Jungle Gym or the Big Jungle Gym.



For the Big Jungle Gym, a nice option is to use six corner shelves...

The measurements are:

- (1) 26" pvc pole for the front
- (2) 19" pvc poles for the sides.

Assemble as shown with two 45 degree angle connectors joined in the rear corner, and one 90 degree connector joined with a 45 degree connector on each side.

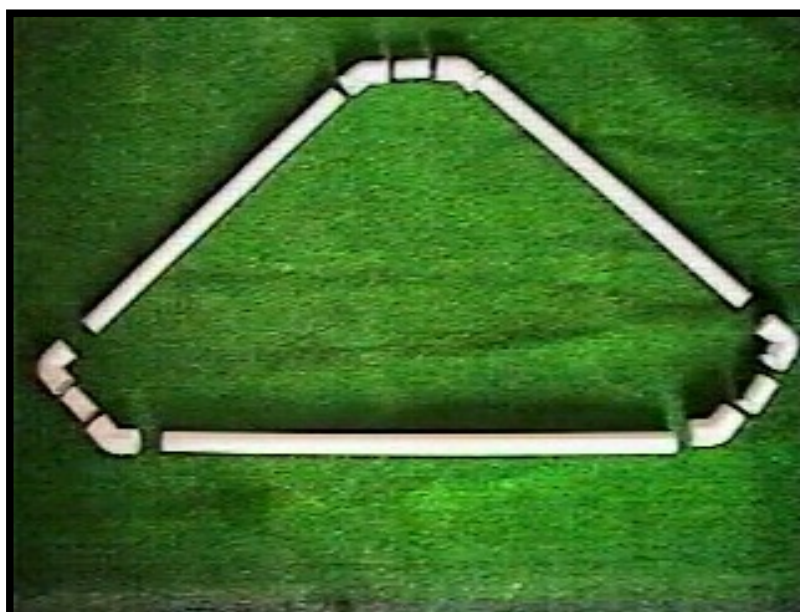

Use three 1 3/4" pvc sections to join the connectors.

Next, cut a piece of plastic mesh to fit the frame.

To keep the mesh from rolling, I attach it with a couple of ties, while I cut it down the center of the pvc poles.

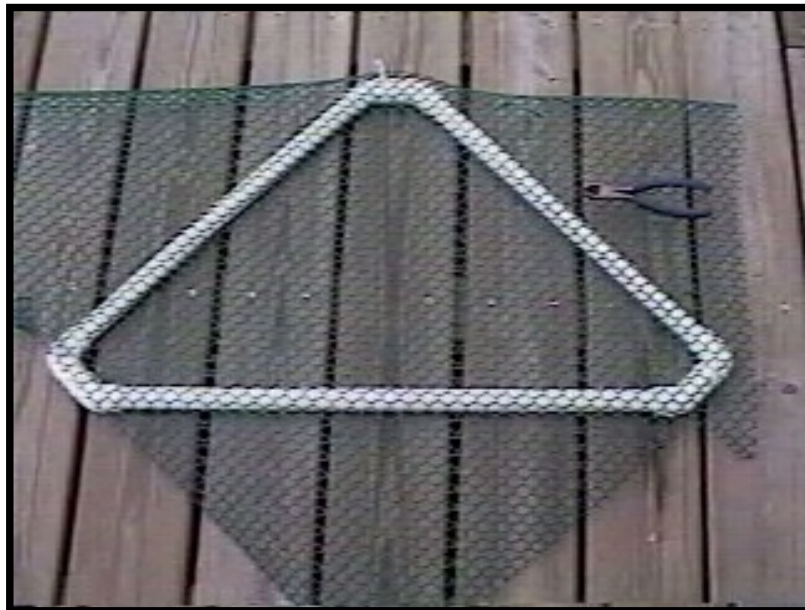

Once the mesh is cut to size, attach it to the frame with ties every 4 or 5 inches. Clip the excess tail ends from the ties.



Using 3/4 pipe insulation, cover the frame.

This adds thickness to the shelves, as well as helping keep the bamboo in place (from spinning when climbed on) on the lower shelves - the ones without floors.



The bamboo has been cut into 7" wide strips and then had the outer two bamboo sticks removed so that the remaining wire can be twisted together and folded under.



The 6 1/2" bamboo strips can be cut to size with strong scissors.

Use 11" black cable ties over the bamboo.

Pull the ties tight with pliers so that the tails are underneath the shelf and clip the tails off.



Make four more of these, omitting the floor. For the chains, make 17 sections of 9 links each to connect each shelf.

The bottom shelf only gets two chain lengths -- up front.

Attach single, open links to the cage frame top with cable-ties, then just lift the stack of shelves into the cage and hang them from the open links.

This allows you to easily install or remove the shelves, just by lifting them off of the open links cable-tied to the cage frame.

Use the same 'open link' technique at the floor level to stretch the shelves across the cage so that they cascade down under the Basking Hammock.



This allows you to unhook the shelves and let them just hang straight down in the enclosure, giving you room to step into the cage for cleaning or spending a little quality time with your iguana.

To make the Basking Hammock, just use the same techniques with these measurements:

Cut
(2) 30" pvc poles and
(2) 15" pvc poles.

Assemble with four 90 degree corner connectors.

Add the mesh floor, pipe insulation and bamboo, all held together with cable ties.

Attach chains with 10 or 11 links to the rear corners.

I like to use several extra links in the front chains to create a slight forward angle.

Using the 'open top link' method to hang the shelves also allows you to adjust how close the shelves are to the lights.



No matter what cage you build, the shelves will be your iguana's favorite spot!

.....

Now we're done!

Although a floor would be nice...

I've got a few different ways to handle that project...

[Contents](#)

Cage Floor Alternatives

One easy floor idea is to use a 4 x 4 square of linoleum (or smaller for the Mini Jungle Gym).

And -- it's easy to sponge clean.

A more ambitious project is to make a small deck platform, about 8" high out of 2x8 boards in the shape of the cage, cover it with a piece of tile board (you'll have one 4x4 piece left over from cutting the ceiling piece from a 4x8 sheet). Then make a cut-out for a tub - like the large black cement mixing tubs at Home Depot that sell for \$13 each or the medium size tub for \$6.

Here's one example:

This picture shows a raised mesh floor on the Big Jungle gym frame.

Those two mesh panels let all the mess fall through - keeping the cage clean inside.

The front panel lifts up... to step inside.

Those sliders make it easier to pull the cage out from the corner... to clean underneath.

With the dome lights on top, this enclosure is now 7



1/2 feet tall!

My best floor idea involves using pvc and plastic mesh. The pvc and a handful of 4-way cross connectors and right angle connectors are employed to create a raised base about 10" high - with pvc poles that acts as skids to slide the cage forward and back.

Two floor panels are then made to fit the shape of the floor and plastic mesh is cable-tied to them to create a floor which is then suspended about 8" above the cage floor, leaving room for a tub under the cage.

By securing one panel to the cage frame with cable ties, and the other panel to that one - it works like a trap door - allowing you to lift the floor panel up and step inside the enclosure - or allow access to the tub.

It also works like a trampoline for the lizard, which is nice for when the lizard wants to go crazy, but the best thing is that it keeps the lizard from 'poop-painting', because everything just drops through to the newspaper on a tarp down below. It also adds more height to the enclosure, which is a good thing.

The most attractive floors that I've been shipping have been dark green astroturf cut a little oversized in the shape of the floor. However, the astroturf gets dirty quickly, and it's possible to pull pieces of it off from the edges - creating an 'impaction' hazard if ingested.

I suggest only using those floors like you would a table cloth for the dining room table: only for when guests are coming over. And maybe tape the edges with cloth tape.

Many people just use newspapers over a tarp in the bottom of the floorless cage. I suggest using a piece of thick carpeting or a pad under the tarp to soften the blow of any free-falling done from the basking hammock.

Above all - have Fun!

[Contents](#)

[Main Index](#)

©Iguana.reptile-cage-plans.com reproduced with permission from lizardcages.com

How to Build an Iguana Cage

Jumbo Jungle Gym

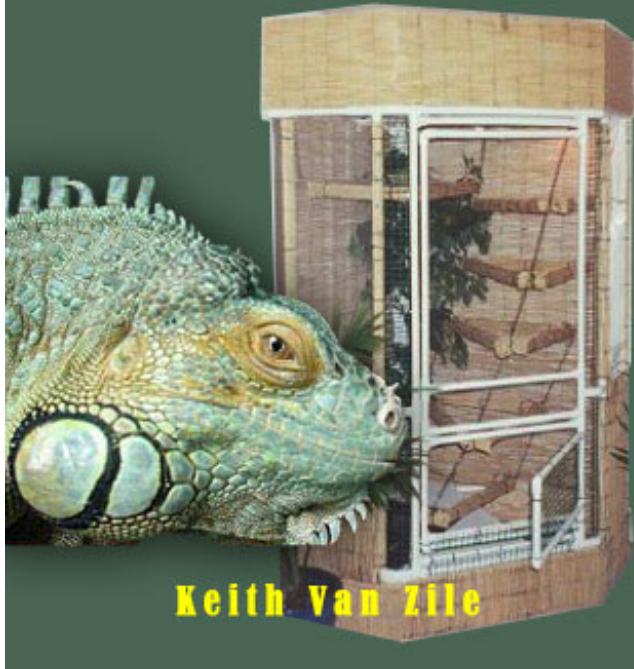

[Main Index](#)

Jumbo Jungle Gym

Contents

[Introduction](#)

[Materials & Measurements List](#)

[Tools](#)

[Measurements](#)

[Building the Jumbo Jungle Gym](#)

[The Frame](#)

[The Door](#)

[Covering with Mesh](#)

[The Ceiling](#)

[Back Panels](#)

[Windows](#)

[Basking Hammock and Shelves](#)

[Floor Alternatives](#)

Introduction

These plans have been compiled from material supplied with permission from Keith Van Zile. They are intended as a guide to creating cages suitable for Iguanas, chameleons and a range of other animals. As with any captive animal it is the responsibility of the owner to create the best possible habitat and conditions for the animals within their care.

Considerable time and expense has gone into creating these plans.

For best results it is recommended that you read through the plans in their entirety before starting to construct the cages.

If you become frustrated or have difficulties, walk away for about 30 min and do something else. Many times when you come back to a difficulty, you will be rewarded with a solution, or at least a better frame of mind.

Have fun with these plans and enjoy your time building something you will be proud of.

[Contents](#)

Materials & Measurements List

Tools

Here are the tools you'll need:

(1) PVC cutting tool. For hand tools, I like the Ridge Tool Company unit, but some people like the tool that looks more like a pruning shear for PVC. They both work well.

I'd avoid attempting to cut all the PVC with a hack saw -- you'll wear yourself out! A jig saw works fine for cutting the PVC, too.

(1) Orbital Jig Saw (about \$29 at Kmart) (1) measuring tape (1) pair clipping pliers (1) sanding block (1) drill (1) straight-edge (1) pair strong scissors

Measurements and Materials (coordinated with the plans):

Jumbo Jungle Gym Materials List & Measurements

- A. 22
- B. 18 3/4"
- C. 34 3/4"
- D. 25 1/4"
- E. 8"
- F. 31 3/4"
- G. 11 3/4"
- H. 33 3/4"
- I. 18 3/4"
- J. 32 3/8"
- K. 28 1/2"
- L. 5"
- M. 33 1/4"

[Contents](#)

3/4" PVC Poles:

Home Depot and Lowes sell them in 10' lengths. You'll need 22, but I'd suggest getting 27, so you have a few extra for shelves and mistakes. They're relatively inexpensive at Lowes. If you have a choice between thicker or thinner poles, I suggest using the thinner ones, known as 'Class 200'. The thinner ones still provide plenty of cage strength since the panel-based design provides a lot of structural support.

Tip: Masking tape is a handy way to hold the bundle of poles together to transport them at the store.

3/4" PVC Pipe Connectors:

These are all the T connectors and Elbows and Angles that you'll find in the plumbing department at Home Depot.

Here's what you'll need:

Number	Part
22	3/4" PVC poles 10' lengths
36	T connectors
4	Oversized T connectors 1" ends + 3/4 middle connector
24	Cross connectors (4 way Ts)
2	90 degree corners (for the door)

32	45 degree connectors
2	rolls of mesh 25' each
1	Bag of 7" cable ties Qty. 500
1	4x8 sheet of paneling for the ceiling, plus recessed light trim rings - or use uncoated wire mesh across the ceiling.

[Contents](#)

Paneling

For the back panels, I use shiny white 1/8" paneling. This 'White Tile Board', is sold in 4x8 sheets, (1/8" thick) at most Home Depots.

Tip:

Home Depot will cut the panels to size FOR you, if you ask. It comes in different designs, too, if you prefer something other than plain white.

It comes in different designs, too, if you prefer something other than plain white.

You'll need three sheets. Unless you have a truck or van to transport them, I suggest going in with the dimensions and having them (Home Depot or Lowes) cut it for you.

TIP:

I usually sketch it out on a piece of paper first - just to make it easy for them.

Windows

For the clear front door window and two side windows,

Front door

For the front door, one Lucite panel covers the top two thirds of the door, and a door-within-a door is a handy bottom addition - although an easy alternative option is to get one sheet of Lucite 72" x 36" and make the whole door clear, instead of making the lower door-within-a-door.

If you use a 32" x 44" sheet, just cut a 6" piece off the long way, and drill holes for cable ties in the corners and every 12" or so, 1/2" in from the edge. An orbital jig saw is the easiest method I've found to cut the Lucite, although you can also score both sides deeply and snap a clean line - if you're lucky.

A sharp drill bit used slowly and very carefully makes clean holes.

TIP: I recommend drilling through the Lucite into a piece of scrap wood underneath to avoid cracking the Lucite. I've found that the least expensive acrylic (Lucite) panels work fine as windows.

One roll of 3' x 5' plastic mesh will give you enough for the two top shelves -- from the Landscaping dept. at Home Depot.

If you want to line the whole cage with mesh as shown with the Basking Cage, Home Depot has 1" mesh in 25' x 40" rolls. You'd need two rolls to line the entire cage. 6' bamboo stakes are a handy way to hold the mesh to the frame using cable ties.

If your lizard is small, I suggest using the dark green 1/2" plastic mesh. from Lowes. Either one cuts easily with strong scissors or cutting pliers (clippers).

Cable Ties

(1) bag of white cable ties 7" long. Qty: at least 500. (Electrical Dept.)

I also use the 11" black cable ties (Qty: 100) to hold the bamboo on the shelves, which are covered in 3/4" pipe insulation (those long black tubes - you'll need (5) 6' lengths of them - marked 'For 3/4" copper pipe'). They give the shelves some thickness under the bamboo.

TIP: When you clip the tail off of the cable ties once they're in place, pull on the tail end hard while clipping it, so that you don't leave a sharp edge. The remaining tail snaps back into the cable tie square - giving it a "smooth shave".

Ceiling

The ceiling takes 4 chrome rings which are actually stove trim rings: 8" trim rings from GE. Part number: PM31X105. At Home Depot. Recessed lighting trim rings also work well, if you'd prefer those.

You'll also need a 2' x 4' roll of un-coated wire cloth, if you'd like a barrier between your lights and the cage. 1/4" works well, although smaller gauges like 1/8" are even easier to work with. You'll need one 10" x 38" swath and one 10" x 10" piece of the wire cloth for your ceiling. You'll see from the ceiling plans how it is used as a barrier to keep the lizard from the lights. Cuts easily with strong scissors.

Mesh and Bamboo for Climbing Sections

If you can't find a roll of bamboo 'Natural Reed Fencing', you can use any suitable alternative, such as the matchstick blinds or bamboo mats from Pier One, or even some brown indoor/outdoor carpeting.

A 4x6 matchstick blind gives you enough material to cover all 6 shelves. If you can find the bamboo fence material - it cuts relatively easily with strong scissors or tin snips.

Home Depot can transfer a roll to your local store from a store that stocks it, for example: from almost any Home Depot in Florida. Lowes has it too: item #147448.

Chains

You'll also need chains. Home Depot and Lowes will cut the Black Decorative chain to length for you. Get 23 feet.

For the front door, get two narrow 3" bolts with nuts.

For convenience, you may want to attach small cords to them with twine and tie them to the cage, so that they don't get lost.

If you opt to make a lower door-within-a-door, get one 4 1/2" bolts instead or use 9" loops of double-sided velcro. Nuts aren't really necessary - the bolts are sufficient to pin the door closed.

[Contents](#)

Shopping List for Jumbo Jungle Gym

Tools and materials:

_____ (1) PVC hand-cutting tool - or -

_____ (1) Jig Saw

_____ (1) measuring tape

_____ (1) Wire clippers

_____ (1) Drill

Number	Part
22	3/4" PVC poles 10' lengths
36	T connectors
4	Oversized T connectors 1" ends + 3/4 middle connector
24	Cross connectors (4 way Ts)
2	90 degree corners (for the door)
32	45 degree connectors
2	rolls of mesh 25' each
1	Bag of 7" cable ties Qty. 500
1	4x8 sheet of paneling for the ceiling, plus recessed light trim rings - or use uncoated wire mesh across the ceiling.

Building the Jumbo Jungle Gym

For this enclosure, you'll need 22 [A] PVC poles.

Let's start with the back middle panel and work around the cage to the front door from there...

To make that narrow panel in the middle of the back of the frame:

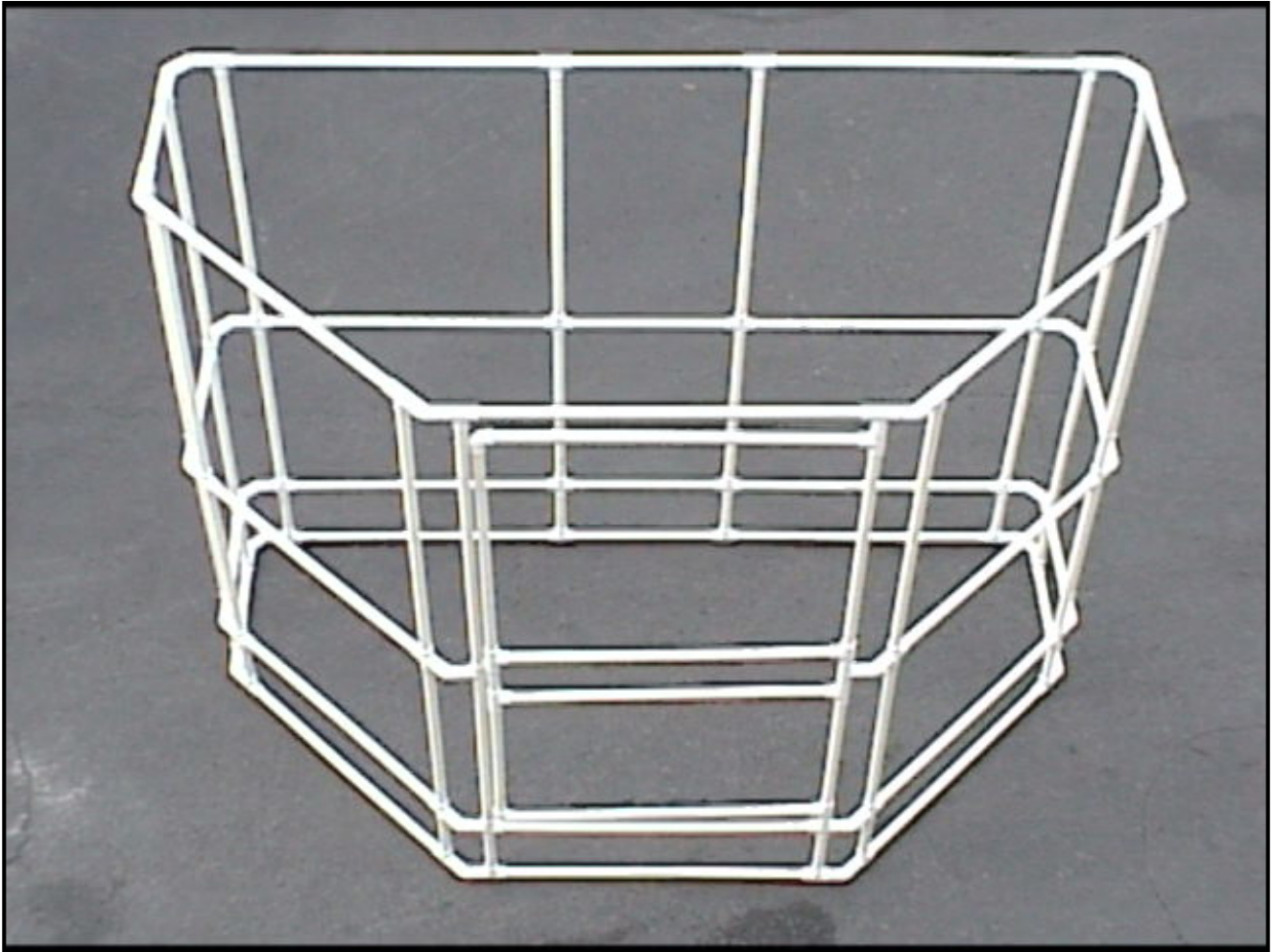

The Frame

Cut the PVC poles into 4 lengths of 18 3/4" [B] for the horizontals, and two lengths of 34 3/4" [C] for the upper verticals (from the top down), and then 2 lengths of 25 1/4" [D] and finally 2 lengths of 8" [E] at the bottom.

The top connectors are just two PVC T connectors facing down.



and in the middle sections are 4-way cross connectors.



and finally, at the floor level, put two T's on the bottom, facing up.

For this cage design, you need to push each PVC joint as tight as it'll go. The trick to that is to use your body weight to push the connectors onto the PVC.

Moving forward... on either side of that narrow back panel is a larger panel. Cut and assemble these panels to complete the entire back of the cage.



The eight long horizontals are all 31 3/4" [F] lengths of PVC.

The vertical poles are the same as on the first panel you built: 34 3/4" [C], 25 1/4" [D] and 8" [E].

Assemble the three panels together and push every joint tightly into each connector. The best way to do this is to turn the entire cage back structure on its side and lean on each joint, then turn it again and lean on each joint again, and repeat until they're all tightly fit together.

Corners are just two forty-

five degree PVC angle connectors joined by a 1 3/4" length of PVC with two more PVC 1 3/4" plugs in the ends.

You'll need to make eight of these corners.

The right and left side narrow panels are easy to make:

Cut the PVC poles into 4 lengths of 11 3/4" [G] for the horizontals, and two lengths of 34 3/4" [C] for the verticals (from the top down), and then 2 lengths of 25 1/4" [D] and finally 2 lengths of 8" [E] at the bottom..

Connect them all with Ts and 4-ways and lean on every joint from every angle to make everything as tight as it can get.

To make the front large angled panels, it's a repeat of exactly what you did for the back panels:

The long horizontals are 31 3/4" [F]. The vertical poles are 34 3/4" [C], 25 1/4" [D] and 8" [E].

At this point, you can add the 8 corner connectors and 16 half-corners to form the cage frame shape as shown below.



Making the frame was easy!

Next we'll tackle [the door...](#)

[Contents](#)

Building the Jumbo Jungle Gym Front Door

The Front Door is a truly great feature of these cages.

The working hinges are a real convenience, since you need to get in and out of your lizard's enclosure several times a day, and the lower second door is brilliant.

Okay, let's get started.

Now, we'll assemble the door, then push it all tightly together, and *then* attach it the frame.



Let's start building from the ground up...

Cut a pole 33 3/4" [H] long and put a T on each end.

Put two short 8" [E] poles into the Ts and put a 4-way connector on top of each of the short poles, and put another 33 3/4" [H] pole across horizontally.



Now it get's a little trickier...

On the left side, put a 25 1/4" [D] pole, then a T connector facing out (to the left - see where it attaches to the frame),

Then put a 34 3/4" [C] pole on top of that, with a T connector at the ceiling level facing down.

Cut an 33 3/4" [H] pole for the top horizontal and put a T on the other end - also facing down.

You've now got the door frame assembled -- and are ready to tackle the hinges and the doors themselves.

"Good job."
(*Someone* should congratulate you on completing the cage frame!).

The lower section of the door is made up of two short 18 3/4" [I] vertical poles and two 32 3/8" [J] poles all connected as shown with three Ts and one corner connector.

Notice the short pvc

plugs sticking out of the right side Ts...

Be sure to push all those joints together tightly, before pushing in the short plugs.

Those plugs in the right side Ts are slotted to make them work smoothly as hinges.



You can make the slots just by sawing into the plug once it's in the T.



The top section of the door is just like the bottom section - except upside down.

You can construct it with two [K] vertical poles and two [J] horizontal poles, all attached together with three Ts and one corner connector - as shown below.

Push all the door joints

tightly together - then install those right side plugs - and then saw slots in them to make the door hinges work smoothly.



One more thing: there's a small gap that needs to be filled between the top and bottom sections of the door on the left side... so cut a [L] pole and connect the door sections together.

On the right side of the door, it works best to put the middle hinge together, which is just a T in the middle facing out (to the right) and connected to the frame. The top and bottom sections of the door - with their slotted plugs - are installed into that middle T. That's your middle hinge:



The final step is to make two bars that will fill in the space above and below the door. These bars are made with pvc poles cut to [M] length and capped with oversized T connectors (1x1x3/4) that have been trimmed to fit. (One alternative option is to trim a couple of pieces of

plastic gutter guards to fill the openings around the door).



To pin the door shut with 3" bolts, I drill a couple of holes in the left side of the door, near the top and bottom. The nuts aren't really necessary, because the bolts will definitely keep the door pinned shut. However, if you have any concerns about *cage intrusions* of the human variety, you may want to put a *locking clasp* on the door.



Now that you have a cage frame and door completed, let's cover it with plastic mesh to make our cage functional right now!

To do that, all we have to do is cable tie mesh around the frame.

Then we'll add a raised mesh floor, a ceiling, and some nice shelves...

But first, [let's cover the frame with plastic mesh \(it's fun!\) --- >>>](#)

An Awesome Door

If you really want to go the extra mile and make an awesome door here's how...

Use the same techniques you just used and make a small hinged door to fit within the lower opening of the large door.

Start by taking that original right side 16 1/4" pole out and topping it with another T connector with a slotted plug.



Then shorten the pole (cut it to size: 10 1/4") so that another T and slotted plug will fit on the bottom.

Add two 23 1/2" poles horizontally and another 10 1/4" [N] pole, connect with two 90 degree corner connectors, and adjust everything for a nice snug fit.

Use velcro loops to hold the lower door shut, or just drill for a longer bolt - 4 1/2".

Cut four more 1" x 1" x 3/4" Ts in half and make two more gap-filling poles, using two 24 1/2" poles.

Cable tie in a mesh rectangle -- and you've got a safe and easy way to get food in and out of the cage, no matter what mood your iguana is in!

Now that's a great door!

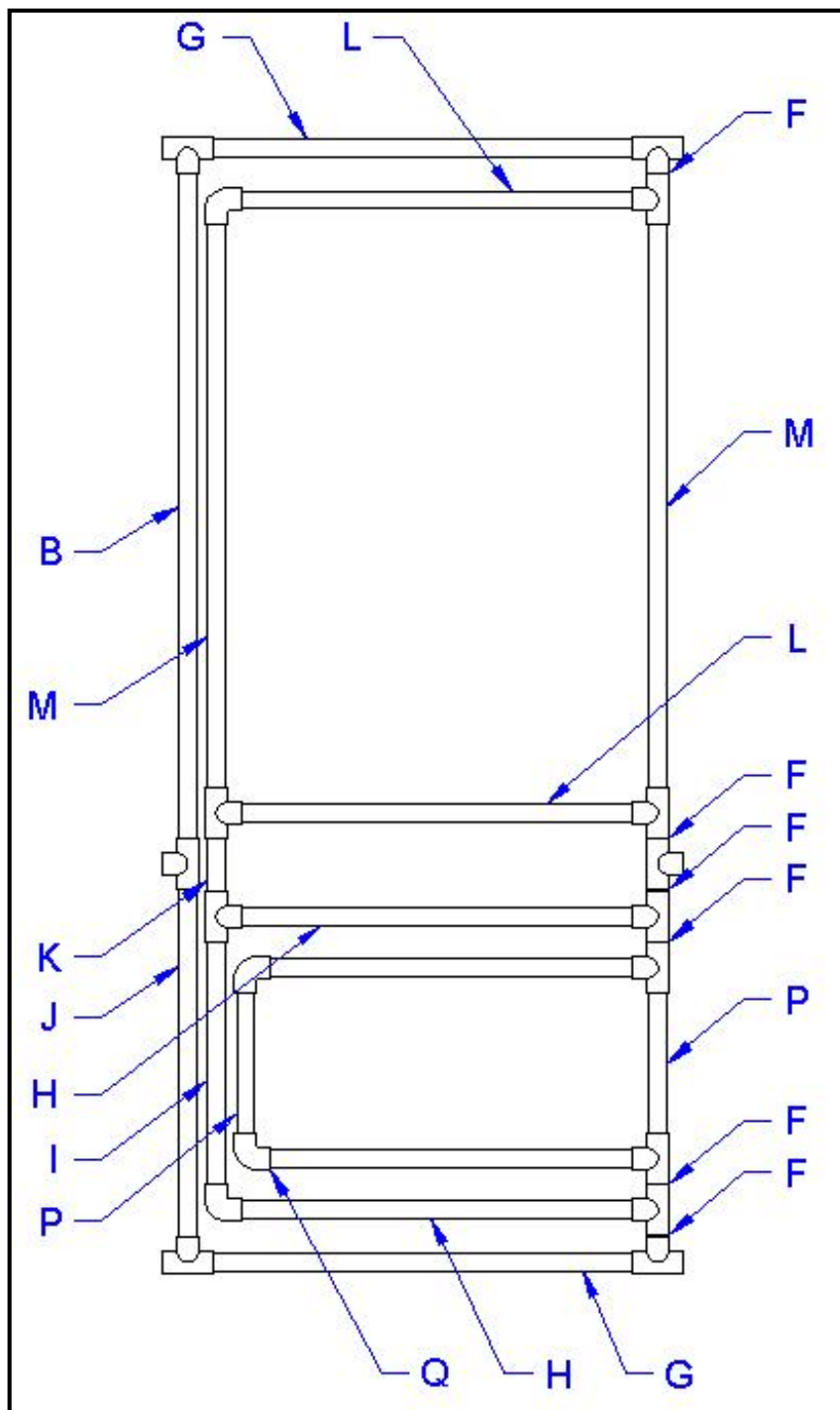

Now we've done the [frame](#), and the [door](#), so next let's do the [ceiling](#), and then the [back panels](#).

Once we've finish the [windows](#) and the [Basking Hammock](#), we're done!

[Contents](#)

Covering the Jumbo Jungle Gym cage with Mesh

One of the clever aspects of this cage design, apart from its *size*, and its *structural integrity*, and its *low cost to build* and its *hinged door*, and the way a 4 x 8 sheet of paneling fits just perfectly on top for a ceiling...

One of *the many clever* aspects of this cage design is that standard 36" rolls of plastic mesh can be attached easily to the frame. That is, 3 foot rolls of mesh fit perfectly onto the 6 foot frame - horizontally.

Even if you intend to eventually cover the frame with solid paneling and clear windows, you still might want to have some mesh around the cage for climbing. Shown at right are two styles of 1/2" mesh that are suitable.



That said, I'm going to go ahead and use my favorite mesh for adult iguanas: 1" green mesh, and not just because it comes in 25 foot rolls for under \$10 at Home Depot, although I do consider that a real bargain.

One 25' roll gets you all the way around the cage once, including the area under the front door, and you'll still have a few extra feet left over.

The second 25' roll gets you all the way around the cage again and still leaves enough to do the door.

Don't throw away any left-over mesh yet, because we've still got a raised floor and some shelves to make.



TIP:

Start with the cable ties down at the floor level first, attaching the ties to the frame every six inches or so. Then do the ties up at the ceiling level. This way, you can use just one cable tie at the middle of the cage where the rolls meet: one tie holds both the top roll of mesh and the bottom roll of mesh to the frame at the horizontal seam that runs around the cage.

Once you finish covering the whole inside of the cage with mesh -- clip the tails off the cable ties.

Or you could finish the cage like below.

[Contents](#)

This cage is 8 feet wide and four feet deep!

As far as I got with designing the Jumbo cage was to work out all the frame measurements and then cover the cage with mesh, which is a quick and easy solution to providing a big habitat, but one guy who bought the plans took it a step further...

He took the Measurements and Materials List and added a white back wall and ceiling, clear front windows and a raised floor. Nice job, Adam!



The raised floor is something that I'd like to see on every one of these cages.

I hope that at least some of the people who buy these plans eventually add a raised floor. It serves several purposes... and they're all good.



There's really only one reason that we go to all of this trouble to make nice big enclosures for our green pets...



We want them to be happy

Building the Jumbo Jungle Gym back panel

This section was not originally in the Jumbo Jungle Gym Plans but we have added it for reference. If you have all of the other plans then you know how is can be created.

The measurements have been removed but you can work them out from the dimensions of the completed cage.

If you are building this cage, it is fairly likely you have built one before and so the directions should be sufficient without the measurements.

The diagrams are clear and the major components and their structure is identical to the other cages. The images are all from the Big Jungle Gym but the principles are identical.

If you do have any enquiries, you can email mark@reptile-cage-plans.com and I will attempt to answer your questions as best I can.

The back panels are pretty easy - especially if you have Home Depot pre-cut the pieces for you!

I cut the large back panels into three pieces for easy shipping...

Although you can just pretend that the seam is not there.



Drill from the shiny side to make holes approximately every 6" to 12", (which are for cable ties to attach the panel to the cage frame.)

The corners are a little trickier, but not much:



As you can see, the holes are drilled so that they line up with each other.

You'll need three of each for the whole cage. That covers the rear corner and the two side corners.

If you look closely, you can see them in rear corner where the two pieces meet.



The best way I've found to join those two pieces is to notch them.

I use a template:

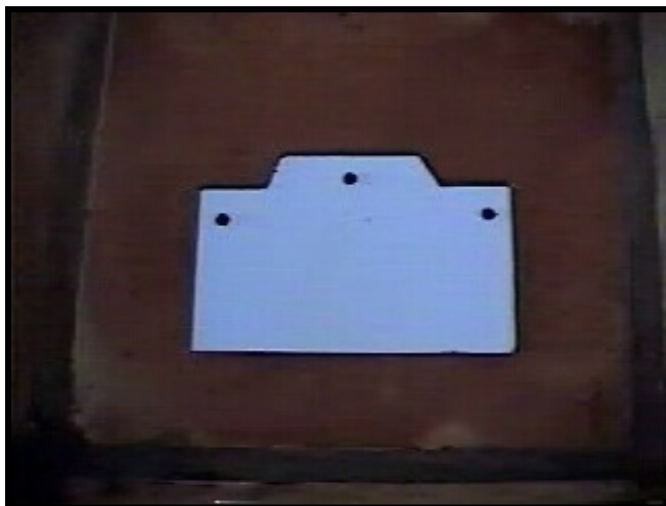

To make the notches: mark $3/4$ " down from the top edges, cut $1\ 1/2$ " in from the side edges, and cut back to the top edge with a $1/2$ " slope.

For the front two mesh inserts... I've been taking 1" green plastic mesh (5 $1/2$ " wide) and lashing it to bamboo poles (68" tall) using jute twine and a locking stitch.



But this a lot of extra work, when all you need to do is to cut and notch more white melamine paneling or clear Lucite. If you do, make these front panels slightly more narrow than the others: just $5\ 1/4$ " wide.



I just happen to think that these mesh panels improve the interaction - and quality of life - of the cage inhabitant.

Maybe you could just use them in the Summer...



The only other melamine pieces you need now are for the lower sides under the windows.

Cut two panels and drill holes that line up with the holes in the lower corner panels. Remember to drill from the shiny side.



Now you can see why I add the bamboo trim. The outside of this melamine paneling is just plain brown.

Isn't this better?



.....

Now we've done [the frame](#), [the door](#), [the ceiling](#) and the [back panels](#).

Now we'll do [the windows](#), and [the hanging shelves](#) and we're done.

[Contents](#)

Adding Windows to the Jumbo Jungle Gym

If you start with two sheets of 32" x 44" [Z] Lucite (or a similar acrylic), you can simply lay the sheets directly on the side panels, lining up the sheet with the center of each PVC pole, and use a marker and a straight-edge to draw the cut lines.



You'll be able to get two side windows out of the one sheet. The other sheet will yield the window portion of the front door.

To cut the Lucite, I prefer an orbital jig saw with very sharp blades although people tell me that scoring both sides deeply and snapping gives a nice clean edge.

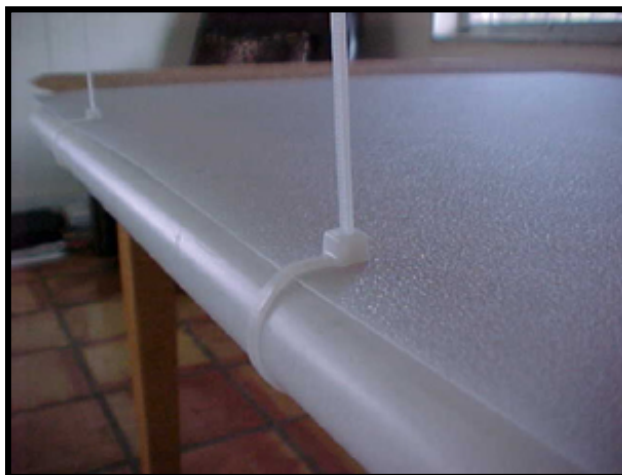

The dimensions of each side window is 15 1/4" x 43 3/4" [AA] and the front door window is 26" x 44" [BB].

I use a sharp drill bit to make holes about a half an inch in from the edges. I like to space them out to match the holes in the white side panels, so that I can use just one cable tie -- through both holes and around the pole, just like we did with the back panels.

Just hold the side window up to the frame and mark where the holes need to be to match up with the back panel holes.

Make sure that the cable tie square ends are flat against the Lucite and clip the excess.

TIP:

Drill, against a piece of scrap wood to avoid cracking the Lucite.

The side window panels are attached to the *outside* of the cage frame, just like the white back panels -- lining up all the holes.

The door window panel, however, is attached to the *inside* of the door frame, so that you have the poles accessible to grasp, to open the door, as well as having access to the bolts that keep the door shut.

TIP:

Take the protective plastic off the Lucite *before* attaching it to the cage frame.

Another tip:

If the cut edges of the Lucite present any dangerously sharp edges, you can use thin white cloth tape to cover the edges all around, nice and neatly.

.....

Now we've done [the frame](#), [the door](#), [the ceiling](#) and the [back panels](#) and [the windows](#). Now all we've got left to do are [the hanging shelves](#), which are *really cool*, and then the [floor](#).

[Contents](#)

Building the Basking Hammock and Shelves

These shelves are my favorite part of the cage to build -- and they add so much style and function -- I just love 'em.

If you read my web page on the history of my cage-building endeavors, you know that I used to build my corner cages completely out of real bamboo.

However, practical considerations have eliminated almost all of the real bamboo from my cages now.

The only bamboo you need for this project is what Home Depot sells as 'Natural Reed Fencing'.

It comes in 6'x 15' rolls for under \$20.

You'll have plenty for the shelves, and enough left over to add some beautiful trim to your new enclosure.

(Home Depot will transfer a roll to your local HD store, if you ask. Florida HD stores carry this year 'round.)

If you're making this cage-building project a family affair, you can get someone started on making these shelves right off the bat.



Let's start with the corner shelves...
These shelves fit well in either cage: the Jumbo Jungle Gym or the Big Jungle Gym.

For the Jumbo Jungle Gym, a nice option is to use six corner shelves...



The measurements are:

- (1) 26" PVC pole for the front
- (2) 19" PVC poles for the sides.

Assemble as shown with two 45 degree angle connectors joined in the rear corner, and one 90 degree connector joined with a 45 degree connector on each side.

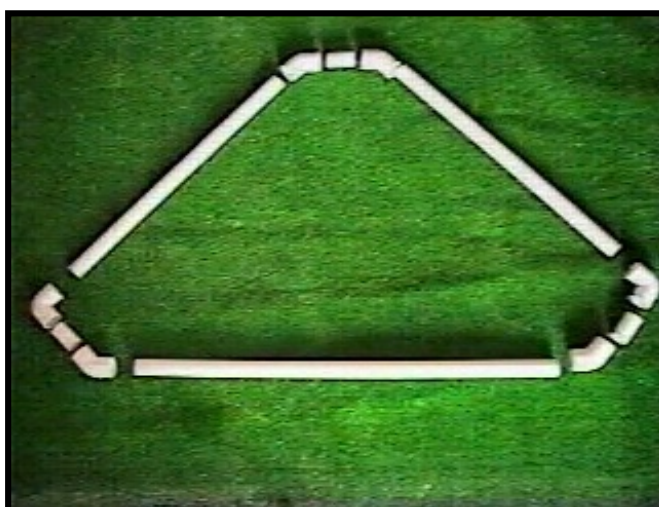

Use three 1 3/4" PVC sections to join the connectors.

Next, cut a piece of plastic mesh to fit the frame.

To keep the mesh from rolling, I attach it with a couple of ties, while I cut it down the center of the PVC poles.

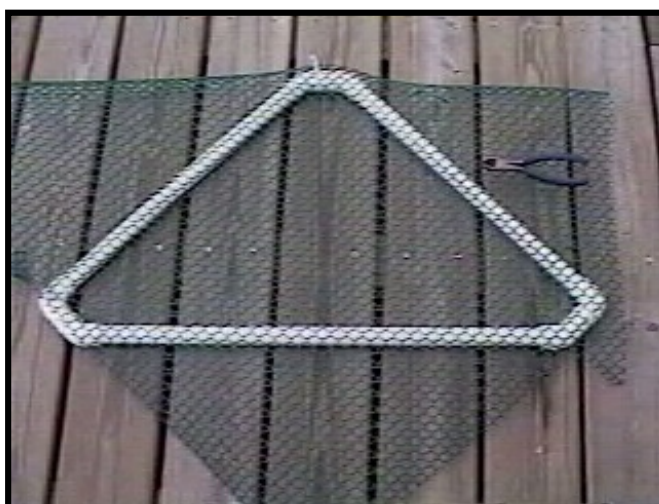

Once the mesh is cut to size, attach it to the frame with ties every 4 or 5 inches. Clip the excess tail ends from the ties.

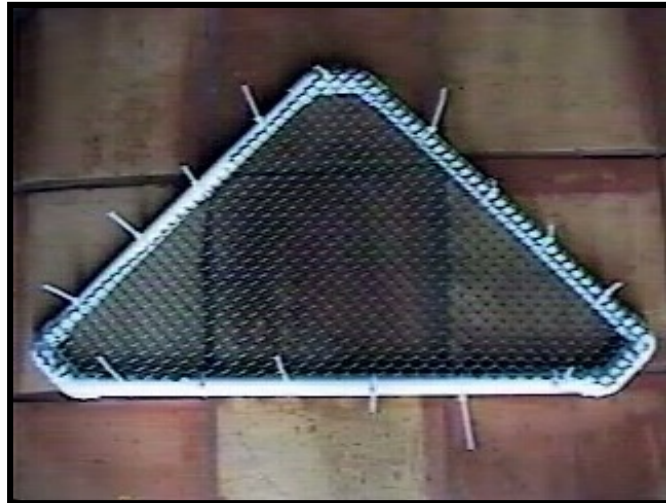

Using 3/4 pipe insulation, cover the frame.

This adds thickness to the shelves, as well as helping keep the bamboo in place (from spinning when climbed on) on the lower shelves - the ones without floors.



The bamboo has been cut into 7" wide strips and then had the outer two bamboo sticks removed so that the remaining wire can be twisted together and folded under.



The 6 1/2" bamboo strips can be cut to size with strong scissors.

Use 11" black cable ties over the bamboo.

Pull the ties tight with pliers so that the tails are underneath the shelf and clip the tails off.



Make four more of these, omitting the floor. For the chains, make 17 sections of 9 links each to connect each shelf.

The bottom shelf only gets two chain lengths -- up front.

Attach single, open links to the cage frame top with cable-ties, then just lift the stack of shelves into the cage and hang them from the open links.

This allows you to easily install or remove the shelves, just by lifting them off of the open links cable-tied to the cage frame.

Use the same 'open link' technique at the floor level to stretch the shelves across the cage so that they cascade down under the Basking Hammock.

This allows you to unhook the shelves and let them just hang straight down in the enclosure, giving you room to step into the cage for cleaning or spending a little quality time with your iguana.



To make the Basking Hammock, just use the same techniques with these measurements:

Cut
(2) 30" PVC poles and
(2) 15" PVC poles.

Assemble with four 90 degree corner connectors.

Add the mesh floor, pipe insulation and bamboo, all held together with cable ties.



Attach chains with 10 or 11 links to the rear corners.

I like to use several extra links in the front chains to create a slight forward angle.

Using the 'open top link' method to hang the shelves also allows you to adjust how close the shelves are to the lights.

No matter what cage you build, the shelves will be your iguana's favorite spot!

.....

Now we're done!

Although a floor would be nice...

I've got a few different ways to handle that project...

[Contents](#)

Cage Floor Alternatives

One easy floor idea is to use a 4 x 4 square of linoleum (or smaller for the Jumbo Jungle Gym).

And -- it's easy to sponge clean.

A more ambitious project is to make a small deck platform, about 8" high out of 2x8 boards in the shape of the cage, cover it with a piece of tile board (you'll have one 4x4 piece left over from cutting the ceiling piece from a 4x8 sheet). Then make a cut-out for a tub - like the large black cement mixing tubs at Home Depot that sell for \$13 each or the medium size tub for \$6.

Here's one example:

This picture shows a raised mesh floor on the Big Jungle gym frame.

Those two mesh panels let all the mess fall through - keeping the cage clean inside.

The front panel lifts up... to step inside.

Those sliders make it easier to pull the cage out from the corner... to clean underneath.



With the dome lights on top, this enclosure is now 7 1/2 feet tall!

My best floor idea involves using PVC and plastic mesh. The PVC and a handful of 4-way cross connectors and right angle connectors are employed to create a raised base about 10" high - with PVC poles that acts as skids to slide the cage forward and back.

Two floor panels are then made to fit the shape of the floor and plastic mesh is cable-tied to them to create a floor which is then suspended about 8" above the cage floor, leaving room for a tub under the cage.

By securing one panel to the cage frame with cable ties, and the other panel to that one - it works like a trap door - allowing you to lift the floor panel up and step inside the enclosure - or allow access to the tub.

It also works like a trampoline for the lizard, which is nice for when the lizard wants to go crazy, but the best thing is that it keeps the lizard from 'poop-painting', because everything just drops through to the newspaper on

a tarp down below. It also adds more height to the enclosure, which is a good thing.

The most attractive floors that I've been shipping have been dark green astroturf cut a little oversized in the shape of the floor. However, the astroturf gets dirty quickly, and it's possible to pull pieces of it off from the edges - creating an 'impaction' hazard if ingested.

I suggest only using those floors like you would a table cloth for the dining room table: only for when guests are coming over. And maybe tape the edges with cloth tape.

Many people just use newspapers over a tarp in the bottom of the floorless cage. I suggest using a piece of thick carpeting or a pad under the tarp to soften the blow of any free-falling done from the basking hammock.

Above all - have Fun!

[Contents](#)

[Main Index](#)

©Iguana.reptile-cage-plans.com reproduced with permission from lizardcages.com